

REVIEW

Osteoporosis, genetics and hormones

R Rizzoli, J-P Bonjour and S L Ferrari

Division of Bone Diseases, WHO Collaborating Center for Osteoporosis and Bone Diseases,
Department of Internal Medicine, University Hospital, 1211 Geneva 14, Switzerland

(Requests for offprints should be addressed to R Rizzoli, Division of Bone Diseases,
Department of Internal Medicine, University Hospital, CH-1211 Geneva 14, Switzerland;
Email: rizzoli@cmu.unige.ch)

INTRODUCTION

Osteoporosis is a systemic skeletal disease characterized by low bone mass and microarchitectural deterioration of bone tissue. At a given age, bone mass results from the amount of bone acquired during growth, i.e. the peak bone mass (Bonjour *et al.* 1991, Theintz *et al.* 1992) minus the age-related bone loss which particularly accelerates after menopause. The rate and magnitude of bone mass gain during the pubertal years and of bone loss in later life may markedly differ from one skeletal site to another, as well as from one individual to another. Bone mass gain is mainly related to increases in bone size, that is in bone external dimensions, with minimal changes in bone microarchitecture. In contrast, postmenopausal and age-related decreases in bone mass result from thinning of both cortices and trabeculae, from perforation and eventually disappearance of the latter, leading to significant alterations of the bone microarchitecture (Fig. 1).

Peak bone mass acquisition

Before puberty, there is no consistent gender-related difference in bone mass at any skeletal site (Glastre *et al.* 1990, Bonjour *et al.* 1991, Geusens *et al.* 1991). Indeed, there is no evidence for a gender-related difference in bone mineral density (BMD; g/cm^2) at birth (Trotter & Dixon 1974), and this similarity in bone mass between males and females is maintained until the onset of pubertal maturation (Gilsanz *et al.* 1988, 1991, 1998). During puberty, bone mineral mass of skeletal sites such as the lumbar spine more than doubles (Bonjour *et al.* 1991, Theintz *et al.* 1992). This

increase occurs approximately 2 years earlier in females than in males (Fig. 2). Meanwhile, a gender-related difference in peak bone mass becomes detectable. This difference appears to result essentially from a longer period of bone mass gain in males than in females, resulting in a larger increase in bone size and cortical thickness in the former (Seeman 1997). Thus, the peak bone mineral content (BMC; g) at the lumbar spine and the proximal femur is higher in males than in females, whereas volumetric bone density (g/cm^3) does not differ between genders at the end of pubertal maturation (Gilsanz *et al.* 1988, 1991, 1997, 1998). On the other hand, black people have greater volumetric bone density than white individuals (Gilsanz 1998, Gilsanz *et al.* 1998); trabecular number is similar, but the trabeculae appear to be thicker in black people (Han *et al.* 1996). Moreover, the cross-sectional area of the mid-femoral shaft is greater in black than in white individuals for an identical cortical thickness (Gilsanz *et al.* 1998).

There is an asynchrony between the gain in statural height and the gain in bone mass (Bonjour *et al.* 1991, Theintz *et al.* 1992, Fournier *et al.* 1997). The peak of statural growth velocity precedes the peak of maximal bone mass gain. In males, the greatest difference occurs in the 13- to 14-year age group and is more pronounced for the lumbar spine and femoral neck than for the mid-femoral shaft, whereas in females it occurs in the 11- to 12-year age group, corresponding in both genders to pubertal stages P2–P3 (Theintz *et al.* 1992). In healthy Caucasian females with apparently adequate intakes of energy, protein and calcium, bone mass accumulation can virtually be completed before the end of the second decade at both the lumbar spine and the femoral neck (Bonjour *et al.* 1991, Katzman

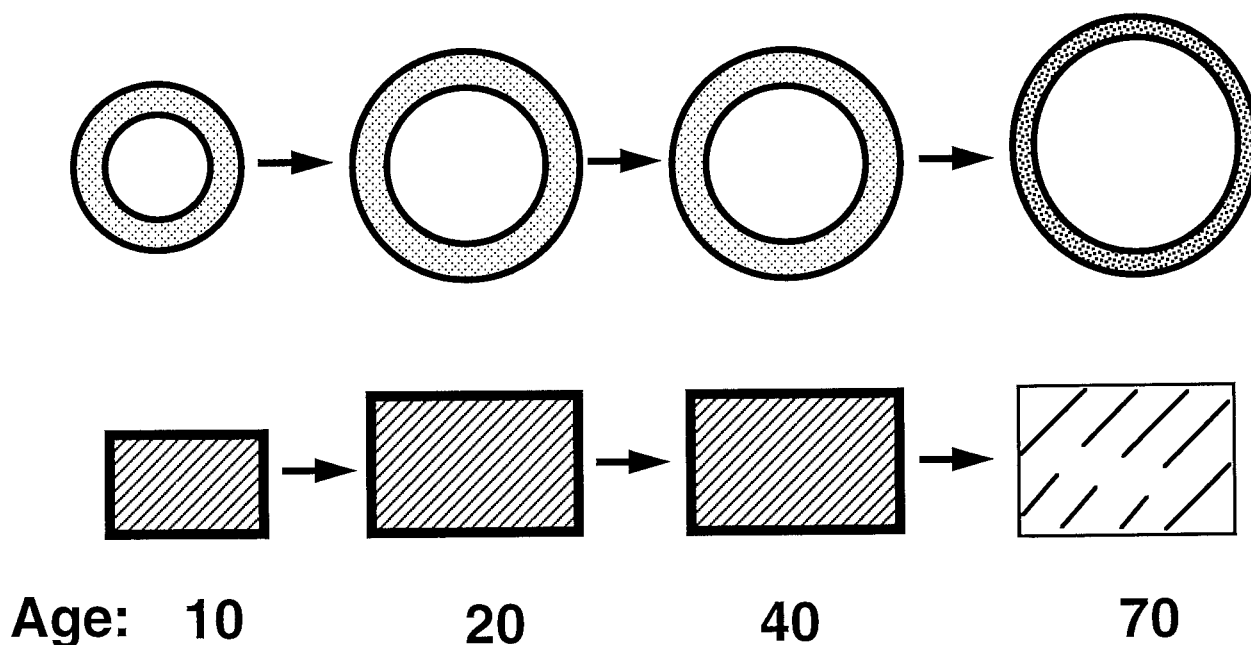

FIGURE 1. Schematic representation of cortical and cancellous bone changes throughout life. Stippling represents cortical porosity and hatching represents cancellous bone network.

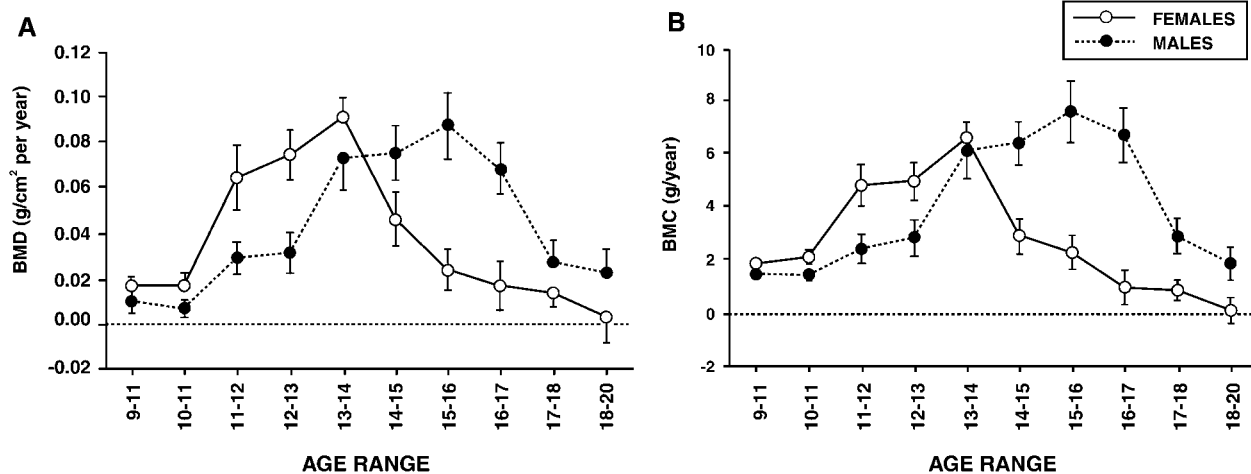

FIGURE 2. Mean \pm S.E.M. bone mass gain of the lumbar spine during adolescence (A: lumbar vertebrae L2-L4 BMD; B: lumbar vertebrae L2-L4 BMC). Reproduced with permission from Theintz *et al.* (1992).

et al. 1991, Theintz *et al.* 1992, Matkovic *et al.* 1994). In males, cortical bone mass may still increase by a few percent beyond the age of epiphyseal plate closure (Parsons *et al.* 1996).

Bone loss

Some bone loss seems to occur at distinct skeletal sites, such as the proximal femur, well before menopause (Riggs *et al.* 1986, Mazess *et al.* 1987,

Rodin *et al.* 1990, Luckey *et al.* 1996, Slemenda *et al.* 1996a). After peak bone mass is achieved, bone size varies little throughout life; a slight expansion of adult bone cortices can be found mainly in men (Garn *et al.* 1967, 1968, Mosekilde & Mosekilde 1990, Seeman 1997). However, this periosteal expansion is less than the increase in bone marrow space resulting from the endosteal resorption which increases with age in both genders. Under these conditions, bone cortex becomes

thinner (Fig. 1). This phenomenon, together with an increment in cortical porosity (Laval-Jeantet *et al.* 1983, Han *et al.* 1996) and a destruction of trabeculae, through thinning and perforation, account for the age-dependent bone loss. It is now clearly established that bone loss does not attenuate with age, but continues throughout life, at least in peripheral skeletal sites (Ensrud *et al.* 1995).

ENDOCRINE REGULATION OF BONE MASS

Many factors, more or less dependent on each other, are known to influence bone mass accumulation during growth. These determinants classically include genetic factors, which quantitatively appear the most prominent factors (Ferrari *et al.* 1998a, 1999), race, gender, nutrients (calcium, protein, phosphate), endocrine factors (sex steroids, calcitriol, insulin-like growth factor-I (IGF-I)), mechanical forces (physical activity, body weight), and exposure to risk factors (Bonjour & Rizzoli 1996, Gilsanz 1998). Most of these factors are also involved in the maintenance of bone mass during adulthood as well as in bone loss later in life, although in variable proportions compared with their role in peak bone mass acquisition.

The vitamin D system

Vitamin D₃ is for the most part synthesized from its 7-dehydrocholesterol precursor in the dermis under ultra violet B radiations. It is sequentially hydroxylated by liver and kidneys in its hormonal metabolite, calcitriol, i.e. 1,25-dihydroxyvitamin D (1,25(OH)₂ D₃). The effects of 1,25(OH)₂ D₃ are mediated by its nuclear vitamin D receptor (VDR). Upon binding of 1,25(OH)₂ D₃, VDR forms a heterodimeric complex with the retinoic acid receptor and additional transcription factors, and ultimately regulates the expression of a number of genes bearing vitamin D responsive elements in their promoter region (for review see Christakos *et al.* 1996, Haussler *et al.* 1997). The role of vitamin D metabolites is primarily to maintain serum calcium and phosphate levels by directly promoting intestinal absorption of these ions as well as by activating bone resorption (for review see Reichel *et al.* 1989).

Failure of the vitamin D endocrine system during growth causes rickets, which is a prominent bone-deforming and sometimes life-threatening disorder. Vitamin D is also important in the maintenance of skeleton integrity in adults. Elderly people tend to have poor dairy calcium and vitamin D intakes, decreased sunlight exposure and dermal

production of vitamin D, and diminished production of 1,25(OH)₂ D₃ with secondary hyperparathyroidism. In turn, vitamin D and calcium supplementation has been demonstrated to significantly increase BMD and decrease the incidence of osteoporotic fractures in the elderly (Chapuy *et al.* 1992, Chevalley *et al.* 1994, Dawson-Hughes *et al.* 1997).

Estrogens

Female sex hormones appear to be mandatory, not only for the acquisition of peak bone mass in both females and males (Smith *et al.* 1994, Carani *et al.* 1997, Vanderschueren *et al.* 1997), but also for the maintenance of bone mass in adults. They control bone remodeling during reproductive life in females (Rizzoli & Bonjour 1997, Riggs *et al.* 1998) and later on in aging men (Slemenda *et al.* 1996b, 1997, Greendale *et al.* 1997). Pathologic conditions associated with premature estrogen deficiency, such as anorexia nervosa, secondary amenorrhea due to strenuous exercise, or the use of inhibitors of gonadotropin secretion, further support the concept of a causal link between estrogen deficiency and accelerated bone loss (Drinkwater *et al.* 1984, Seeman *et al.* 1992). By indirectly accelerating bone turnover and by uncoupling bone formation from resorption (Manolagas 1998), estrogen deficiency is the main cause of postmenopausal osteoporosis, and possibly plays an important role in male osteoporosis as well (Bilezikian *et al.* 1999). Thus, estrogen deficiency is directly implicated in the age-related increase in the incidence of fragility fractures (Riggs *et al.* 1998). In addition, estrogen deficiency also seems to be correlated with the progressive increase in serum parathyroid hormone (PTH) levels observed in aging individuals, which by itself contributes to accelerate bone turnover (Khosla *et al.* 1997).

IGF-I

IGF-I is an essential factor for longitudinal bone growth (Froesch *et al.* 1985), as it stimulates proliferation and differentiation of chondrocytes in the epiphyseal plate (Canalis *et al.* 1991). IGF-I also plays a role in trabecular and cortical bone formation. This factor can stimulate both proliferation and differentiation of osteoblasts; it increases type I collagen synthesis, alkaline phosphatase activity and osteocalcin production (Schmid & Ernst 1992). Thus, IGF-I can exert anabolic effects on bone mass not only during growth, but also during adulthood (Rosen & Donahue 1995, Ammann *et al.* 1996, Bagi *et al.* 1996, 1997).

Furthermore, by its renal action on tubular reabsorption of phosphate and on the synthesis of calcitriol, through a direct action on renal cells (Caverzasio & Bonjour 1989, Caverzasio *et al.* 1990), IGF-I can be considered as an important controller of the intestinal absorption and of the extracellular concentration of both calcium and phosphate, the main elements of bone mineral. On the other hand, IGF-I can selectively stimulate the transport of inorganic phosphate across the plasma membrane in some osteoblastic cell lines (Palmer *et al.* 1996, 1997). Osteogenic cells not only express specific IGF-I receptors, but they can also be endowed with IGF-I producing machinery (Canalis *et al.* 1991, Chevalley *et al.* 1998). Taking into account these experimental and clinical observations, IGF-I could play a prominent role in the pathophysiology of osteoporosis, of osteoporotic fracture and of its complications. In association with age, several reports have documented a decrement in IGF-I plasma levels (Hammerman 1987, Quesada *et al.* 1992, Goodman-Gruen & Barrett-Connor 1997, Langlois *et al.* 1998). Under these conditions, a restoration of this altered system in the elderly, for instance by protein replenishment (Schürch *et al.* 1998), is likely to favorably influence not only BMD, but also muscle mass and strength, since these two variables are important determinants of the risk of falling (Aniansson *et al.* 1984, Castaneda *et al.* 1995).

Thus, bone mass gain during childhood, bone loss after menopause and further loss in the elderly are determined by different sets of endogenous and exogenous factors (Ralston 1997, Seeman & Hopper 1997), and the relative influence of specific genes on the risk of osteoporosis may vary greatly with age. We will now examine the genetic aspects of hormones and their receptors involved in the regulation of bone accumulation and loss.

GENETIC DETERMINANTS OF OSTEOPOROSIS

Definition of the variable

Although areal BMD is a continuous variable, an operational definition of osteoporosis considers the disease as a BMD below -2.5 s.d. from the mean BMD of young adults for skeletal sites such as lumbar spine or proximal femur as evaluated by dual energy X-ray absorptiometry (DXA) (Kanis *et al.* 1996). This is the phenotypic trait (Rizzoli *et al.* 1995) that is most commonly used in studies evaluating heritability or polymorphic gene markers of osteoporosis. However, in order to

understand the genetic basis for decreased bone strength, and ultimately osteoporotic fractures, one might eventually need to assess the inheritance of, and identify the specific genes associated with, a multitude of skeletal and extraskeletal traits, such as bone size, shape and microarchitecture (Turner *et al.* 2000), body weight (the single most influential variable correlated with BMD), muscle strength, biochemical variables of calcium and phosphate homeostasis, ovarian function, etc. Moreover, the clinical expression of osteoporosis is represented by the skeletal fracture. A fracture is a stochastic event which is determined by both bone-related factors (mass, size, architecture, microarchitecture, intrinsic properties of bone material) and bone-independent factors (falls, protecting responses, soft tissue padding, etc.) (Pinilla *et al.* 1996). The latter may have their own heritable and non-heritable components, which increases even further the complexity of the genetic determination of osteoporotic fractures (Kelly *et al.* 1990, Kannus *et al.* 1999, Zmuda *et al.* 1999).

Hereditability of bone mass

It has been shown that daughters of osteoporotic women have a low BMD (Seeman *et al.* 1989). A study comparing peak bone mass at both the lumbar spine and femoral neck in young adult daughters from peri- and early postmenopausal women with decreased BMD and in daughters of women with normal BMD showed a decreased BMD among the former (Barthe *et al.* 1998). BMD is decreased among the relatives of 38 middle-aged men with severe idiopathic osteoporosis (Cohen-Solal *et al.* 1998). These studies confirm the importance of a familial history of osteoporosis in the screening of subjects at risk and suggest the expression of inherited determinants of the risk of osteoporosis from an early age on. A history of fracture is associated with a more than twofold increase in the risk of subsequent fracture (Klotzbuecher *et al.* 2000). In order to investigate the proportion of the BMD variance across the population explained by genetic factors, which is known as the heritability (Kelly *et al.* 1995), mainly two human models have been used. In the twin model, within-pairs correlations for BMD are compared between monozygotic (MZ) twins, who by essence share 100% of their genes, and dizygotic twins (DZ), who have 50% of their genes in common. Stronger correlation coefficients among adult MZ as compared with DZ twins are indicative of the genetic influence on peak bone mass, accounting for as much as 80% of lumbar spine and proximal femur

BMD variance (Pocock *et al.* 1987). The influence of environmental and genetic factors on bone mass, but also on lean and fat mass has recently been reassessed in 102 female twin pairs (mean age \pm s.d. 52.8 ± 13 years) from the Sydney Twin Study of Osteoporosis (Nguyen *et al.* 1998). Results indicate that 80% and 65% of variance of lean mass and fat mass, respectively, were attributable to genetic factors. However, genetic factors affecting lean and fat mass had only little influence on BMD at the lumbar spine or femoral neck. These results differ from the previous evidence of indirect genetic effects on bone mass occurring through the determination of lean body mass (Seeman *et al.* 1996). Hence it remains presently unclear whether the relation between lean mass and bone mass is most significantly determined by environmental or genetic influences.

Parent-offspring comparisons have also shown significant relationships for BMD, albeit heritability estimates have been somewhat lower (in the range of 60%) than in the twin model (Tylavsky *et al.* 1989). Actually, the magnitude of direct genetic effects on peak bone mass as evaluated in both human models may be overestimated by similarities in environmental covariates (Slemenda *et al.* 1991, Krall & Dawson-Hughes 1993). We investigated correlations for BMC, areal and volumetric BMD and bone area in the lumbar spine and femur (neck, trochanter and diaphysis) in 138 premenopausal women (mean age \pm s.d., 40.0 ± 4.0 years) and their prepubertal daughters (8.1 ± 0.7 years) (Ferrari *et al.* 1998b). Regressions were adjusted for height, weight and calcium intake, to minimize the impact of indirect genetic effects as well as of dietary influences on bone mineral mass resemblance among relatives. The results indicate that despite great disparities in the maturity of the various constituents of bone mass before puberty with respect to peak adult values, heredity by maternal descent is detectable at all skeletal sites and affected virtually all bone mass constituents, including bone size and volumetric mineral density. Moreover, when the daughters' bone values were re-evaluated 2 years later, while puberty had begun and bone mineral mass had considerably increased, measurements were highly correlated with prepubertal values (all $r > 0.80$) and mother-daughter correlations had remained unchanged. By the age of 16–18 years in females and 18–20 years in males, bone mass gain virtually ceases, but a marked scattering of BMD values for both genders is then apparent across the population (Bonjour *et al.* 1991, Theintz *et al.* 1992). Thus, a major proportion of this variance is due to genetic factors which are already expressed before puberty with subsequent tracking

of bone mass constituent through the phase of rapid pubertal growth until peak bone mass is achieved.

A twin study using quantitative ultrasound to evaluate bone properties in the phalanges and calcaneum has shown heritability values ranging from 55% to 82%, which is similar to BMD values estimated by DXA at the lumbar spine and femoral neck level (Danielson *et al.* 1999). However, cross-trait correlations suggested that specific genes unrelated to BMD explained at least half of the heritability of ultrasound measurements. Hence the risk for osteoporosis and osteoporotic fracture is determined by various sets of genes whose effects may not all be appreciated by one single measurement, such as BMD. Interestingly, it appears that male to male, and male to female inheritance of bone mass may differ substantially (Krall & Dawson-Hughes 1993). It might be hazardous therefore to extrapolate genetic influences on bone mineral mass as identified in women to the male population, in which this question has virtually not yet been investigated.

In contrast to the clear heritability of peak bone mass, the proportion of the variance in bone turnover as well as in postmenopausal and age-related bone loss which depends on genetic factors remains unclear. Twin studies have suggested a higher correlation for bone loss among MZ compared with DZ twins (Kelly *et al.* 1995), but the heritability of bone turnover, as assessed in this model by various markers of bone formation and resorption, appears to be small (Garnero *et al.* 1996a). Interestingly, however, the age at which cessation of the ovarian function occurs, which is a major determinant of the osteoporosis risk (see above), seems to display a strong heritability (63%) (Snieder *et al.* 1998).

Candidate genes versus genome screens

As pointed out before, osteoporosis is very likely to be a polygenic disease, involving a large variety of gene products implicated in both bone modeling (growth) and remodeling (loss). Genetic linkage between BMD and candidate genes has been searched in twin cohorts of unaffected individuals, in large numbers of both affected (osteoporotic) and unaffected unrelated individuals (case controls and association population studies) and, rarely, in osteoporotic probands and relatives. The latter case is best illustrated by the study of Duncan *et al.* (1999) who used a linkage approach to test a number of candidate genes known to be implicated in the control of BMD and/or bone metabolism in 115 probands with osteoporosis and 499 relatives. The candidate genes studied coded for structural

TABLE 1. Frequency of common allelic polymorphisms in candidate hormone or hormone receptor gene loci associated with bone mass

Gene loci	Markers	Genotype frequency	
		Caucasian	Asian
Vitamin D receptor 3' end	<i>BsmI</i>	BB 18%, Bb 46%, bb 36%	BB 1–2%, Bb 21%, bb 77%
	<i>TaqI</i>	TT 36%, Tt 48%, tt 16%	TT 78%, Tt 21%, tt 1%
	<i>ApaI</i>	AA 24%, Aa 46%, aa 28%	AA 9%, Aa 48%, aa 43%
Vitamin D receptor start codon	<i>FokI</i>	FF 36%, Ff 49%, ff 15%	FF 33%, Ff 53%, ff 14%
	<i>PvuII</i>	PP 18%, Pp 53%, pp 29%	PP 18%, Pp 52%, pp 30%
Estrogen receptor	<i>XbaI</i>	XX 10%, Xx 48%, xx 42%	XX 5%, Xx 31%, xx 64%
	<i>BstBI</i>	ND	BB 82%, Bb 17%, bb 1%
Parathyroid hormone	A ¹²²⁰ -G*	Heterozygous 6%	ND
Glucocorticoid receptor exon 2	C ⁴⁴⁷ -T*	RR 49%, Rr 44%, rr 7%	ND
Calcitonin receptor	<i>TaqI</i>	TT 11%, Tt 50%, tt 39%	ND
	CA repeat	ND	(6 genotypes)

Polymorphic markers are designed as endonuclease restriction sites, variable number tandem repeats (VNTR, AT rich), dinucleotide repeats (CA) or sequence variations (*) when primarily identified as single-stranded conformation polymorphisms. Due to the elevated number of genotypes resulting from VNTR and CA repeats, frequencies cannot be shown but the number of most common genotypes is indicated in parentheses. Only published allelic polymorphisms associated with BMD (and/or osteoporosis) are listed (see text for references). Capital letter, absence of restriction site; small letter, presence of restriction site. ND, not determined.

components, such as type I collagen A1 and A2, type II collagen A1, fibrillin type 1, or osteopontin, for growth factors or cytokines, such as colony-stimulating factor 1, epidermal growth factor, interleukin (IL)-1 α , IL-4, IL-6, IL-11, transforming growth factor- β 1 (TGF- β 1), tumor necrosis factor- α and - β , or components of endocrine systems, such as androgen receptor, VDR, calcium-sensing receptor, estrogen receptor (ER)-1, IGF-I, PTH, PTH-related protein (PTHrP), and PTH receptor type 1. The strongest linkage with BMD was detected with the PTH receptor type 1 gene, with a maximal LOD (logarithm of the odds) score of of 2.7–3.5. The ER type 1 gene and the IL-6 gene were among the few other loci to be significantly associated with BMD, but with lower LOD scores.

Alternatively, genome-wide scanning in large kindreds with a clearly defined skeletal phenotype, such as autosomal recessive juvenile onset osteoporosis (Gong *et al.* 1996) or high bone mass (Johnson *et al.* 1997), as well as in the population at large (Koller *et al.* 1998) have been performed. These genome screens have localized important quantitative trait loci linked to bone mass, such as chromosome 11q12–13 (see references above), which now require further studies to eventually identify the specific genes involved.

As far as endocrine systems are concerned, polymorphic candidate genes coding for hormones and/or their receptors known to control calcium/phosphate and bone metabolism have been particularly scrutinized for their association with BMD

and/or osteoporosis in population studies. These studies are reviewed in some detail below.

VDR gene polymorphisms

Among the multiple candidate genes harboring polymorphic loci so far investigated in relation to BMD and/or BMD changes (Table 1), the VDR-3' end alleles (*BsmI*, *ApaI* and *TaqI*) were the first described (Morrison *et al.* 1994) and the most controversial (Hustmyer *et al.* 1994, Garnero *et al.* 1995, 1996b, Cooper & Umbach 1996, Jørgensen *et al.* 1996, Matsuyama *et al.* 1995, Tokita *et al.* 1996, Uitterlinden *et al.* 1996, Zmuda *et al.* 1997, Kikuchi *et al.* 1999). A meta-analysis combining 16 separate studies examined the relationship between VDR genotypes and BMD (Cooper & Umbach 1996). Subjects with the BB genotype had a 2.4%, 2.5% and 1.7% non-significantly lower BMD as compared with bb at the level of the femoral neck, lumbar spine, and distal radius respectively. Regarding vertebral fractures (368 cases and 1548 controls, collected in five studies), the relative risk in BB versus bb subjects varied between 0.7 and 2.5 among studies. All confidence intervals included 1 and none reached a level of statistical significance. For hip fracture, there were 235 cases and 800 controls in two cohorts. Although the relative risk of femoral neck fracture among BB in the Nurses' Health Study was 2.4, reaching statistical significance when older age and lower calcium intake were taken into consideration (Feskanich *et al.* 1998), these results were not confirmed in the Study of

Osteoporotic Fractures, which found a relative risk of 0.8 for BB (Ensrud *et al.* 1999).

Based on the assumption that quantitative ultrasound measurements (QUS) of the calcaneum (broadband ultrasound measurement and speed of sound) might evaluate some properties of bone which differ from BMD at other sites as assessed by DXA, two studies have recently examined the relationship between VDR alleles and QUS in, respectively, 393 women aged 45–53 years (Gregg *et al.* 1999) and 425 postmenopausal women (Giguère *et al.* 2000). No significant association was found between VDR-3' polymorphisms and QUS measurements in either study.

The more recently described association between VDR-5' start codon polymorphism (*FokI*) and BMD, at first observed in small cohorts of postmenopausal Mexican–American women (Gross *et al.* 1996), white premenopausal American women (Harris *et al.* 1997) as well as Japanese women (Arai *et al.* 1997), has not been confirmed in two larger European studies in healthy premenopausal women or prepubertal girls (Eccleshall *et al.* 1998, Ferrari *et al.* 1998d).

Several independent investigators have shown the importance of age, gene–environment interactions and gene–gene interactions to explain the inconsistent relation between bone mineral mass and VDR-3' and -5' genotypes. Thus, significant BMD differences between VDR-3' *BsmI* genotypes were detected in children (Sainz *et al.* 1997, Ferrari *et al.* 1998c), but were absent in premenopausal women from the same genetic background (Ferrari *et al.* 1998c). Moreover, the latter study found that BMD gain in prepubertal girls was increased at several skeletal sites in Bb and BB subjects in response to calcium supplements (800 mg/day), whereas it remained apparently unaffected in bb girls, who had a trend for spontaneously higher BMD accumulation on their usual calcium diet (Ferrari *et al.* 1998c) (Fig. 3). Accordingly, a model taking into account the early influence of VDR-3' polymorphisms, calcium intake and puberty on BMD gain has been proposed to explain the relation between these genotypes and peak bone mass (Ferrari *et al.* 1998a). Interestingly also, several investigators have noted a significantly lower height among women and men with the VDR-3' BB compared with Bb or bb genotypes (Barger-Lux *et al.* 1995, Ferrari *et al.* 1998c, Tao *et al.* 1998, Lorentzon *et al.* 2000). Considering the relationship between body size and bone size, as well as the influence of calcium intake on both body height and bone area during growth (Bonjour *et al.* 1997), it is tempting to speculate that VDR-3' alleles together with environmental calcium might have an indirect and complex influence on

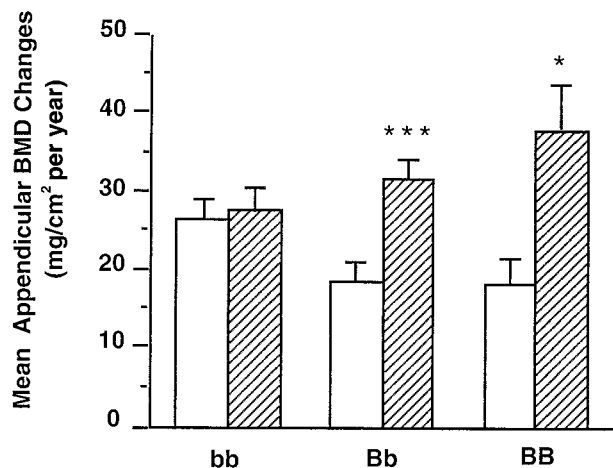

FIGURE 3. Mean BMD changes of five appendicular skeleton sites (radial metaphysis and diaphysis, femoral neck, trochanter and shaft) in prepubertal girls receiving a 850 mg calcium supplement (hatched bars), or a placebo (open bars), during 1 year, according to VDR-3' end genotypes. The results are taken with permission from Bonjour *et al.* (1997) and Ferrari *et al.* (1998a). * $P < 0.05$, *** $P < 0.001$.

peak bone mass through the regulation of skeletal growth. A number of investigators have shown a significant interaction between VDR-3' genotypes and calcium intake on BMD in young adult and postmenopausal women (Salamone *et al.* 1996, Kiel *et al.* 1997, Rubin *et al.* 1999) as well as on BMD changes and/or intestinal calcium absorption in late postmenopausal women (Dawson-Hughes *et al.* 1995, Ferrari *et al.* 1995, Krall *et al.* 1995). The latter observation is particularly important, considering that postmenopausal women with low fractional calcium absorption and low calcium intake are at a significantly increased risk of hip fracture (Ensrud *et al.* 2000). Moreover, VDR-3' alleles have been associated with BMD changes in response to vitamin D supplementation in a small group of elderly women (Graafmans *et al.* 1997).

A short-term dietary intervention trial in young healthy males segregated as alternate homozygous BB and bb according to VDR-3' *BsmI* alleles further suggests that BB subjects may have a subtle resistance to calcitriol leading to significantly higher levels of circulating PTH, decreased tubular reabsorption of inorganic phosphate (Pi) and lower serum Pi levels when their calcium and phosphorus intakes are maintained at the lowest levels for several days (Ferrari *et al.* 1999). In addition, age and dietary calcium intake might also influence the association between VDR-5' start codon polymorphisms and peak bone mass (Ferrari *et al.* 1998d). Moreover, similarly to VDR-3' alleles (see above),

VDR-5' alleles have also been associated with intestinal calcium absorption in children, as evaluated by a radioisotopic method (Ames *et al.* 1999). Altogether, these observations provide a possible physiological mechanism to the relation between VDR gene polymorphisms and bone mass and emphasize the methodological limitations of early studies focusing on the association between VDR genotypes and BMD regardless of the influence of age and environmental factors. Moreover, other potential gene-environmental interactions, such as those involving physical exercise (Gregg *et al.* 1996) as well as gene-gene interactions might further modulate the relationship between VDR gene polymorphisms and bone mass.

Thus, BMD differences (equivalent to 1 s.d.) have been found in prepubertal girls, premenopausal women and young adult males segregated according to both VDR-3' *BsmI* and VDR-5' *FokI* genotypes whereas, taken independently, these polymorphisms were either not associated or only weakly associated with BMD (Ferrari *et al.* 1999). Gene-by-gene interactions have also been found between VDR and ER gene polymorphisms and are examined below.

In summary, VDR-3' and -5' alleles are possibly weak determinants of BMD, their effects being easily confounded by the influence of many other genes and environmental factors. Hence, VDR gene polymorphisms alone are not clinically useful genetic markers of the osteoporosis risk in the elderly. Nevertheless, when examining the effects of calcium on peak bone mass (and particularly bone size) acquisition (bone modeling), or on bone loss (bone remodeling), VDR alleles could be one significant factor to explain some of the variability observed in the population.

ER gene polymorphisms

Genotypes identified by *PvuII* and *XbaI* restriction fragment length polymorphisms in the first intron of the ER α gene (Table 1) were originally found to be significantly associated with BMD in postmenopausal Japanese women, but not with markers of bone turnover (Kobayashi *et al.* 1996). In contrast, a similar study from Korea reported no significant BMD differences among ER genotypes in postmenopausal women receiving hormone replacement therapy (HRT) (Han *et al.* 1997). Whereas the former study suggested that ER gene polymorphisms could be related to the acquisition of peak bone mass, the latter rather suggested an influence, if any, on the rate of bone loss. More recently, another study from Japan including 173 premenopausal to late postmenopausal women indicated a

predominant association between ER genotypes and adult bone mass, which disappeared with advancing age (Mizunuma *et al.* 1997). Several investigators have examined ER gene polymorphisms and bone mass in Caucasian populations as well. In one study, a significant association was found between either the *PvuII* or the *XbaI* genotypes and lumbar spine BMD in 253 pre- and perimenopausal women, those with the *PvuII* pp genotype having a 6.4% lower BMD at this site compared with PP (Willing *et al.* 1998). However, there were no differences in BMD changes, nor in several biochemical markers of calcium and bone metabolism, including PTH and osteocalcin, over a 3-year period in this cohort. One limitation of this study concerning the potential association of ER polymorphisms with postmenopausal bone loss was the very low overall bone loss in this cohort over 3 years ($\leq 1\%$). In contrast, a very recent study which prospectively investigated the 5-year bone loss in early postmenopausal women receiving either HRT or placebo in addition to calcium and vitamin D found no significant differences in BMD among ER polymorphisms at baseline, but significant differences in lumbar spine BMD changes between ER genotypes PP (-6.4%) and pp (-2.9%) in the absence of HRT (Salmen *et al.* 2000). In women receiving HRT, these differences were no more apparent.

A significant gene-by-gene interaction between VDR and ER gene polymorphisms has been suggested by several authors. In the study by Willing *et al.* (1998), BMD at all skeletal sites was lower in subjects with the VDR *BsmI* genotype BB, as compared with Bb and bb, in the subgroup of women carrying the ER *PvuII* genotype PP. Of note however, there were only five VDR/ER BB/PP in this cohort. An interaction between VDR-3' and ER polymorphic loci has also been suggested in relation to BMD in a cohort of 426 normal and osteoporotic early postmenopausal women (Gennari *et al.* 1998). Subjects carrying the VDR/ER BB/PP genotype had a significantly lower BMD at the lumbar spine compared with alternate homozygotes bb/pp. VDR/ER polymorphisms have also been related to the rate of postmenopausal bone loss in a small cohort of women ($n=108$) with or without HRT (Deng *et al.* 1998). These results, however, remain controversial, as a recent study in 313 late postmenopausal women with a low average calcium intake (approximately 600 mg/day), including 142 women with a history of osteoporotic fractures, found no significant relationship between ER polymorphisms alone or in combination with VDR polymorphisms on BMD or a panel of biochemical markers of calcium and bone metabolism (Vandevyver *et al.* 1999).

Altogether, these data suggest that ER α gene alleles *PvuII* (alternatively *XbaI*) may be another possible determinant of bone mass, particularly through their interaction with VDR-3' alleles and estrogen replacement therapy in postmenopausal women. The molecular mechanisms of these potential interactions as well as their value to identify responders versus non-responders to HRT remain completely unknown.

IGF-I gene polymorphisms

The IGF-I gene is a recent new candidate in relation to bone mass (Miyao *et al.* 1998, Rosen *et al.* 1998). Numerous alleles are identified by the number of CA repeats in the vicinity of promoting regions in the IGF-I gene, 1 kb upstream from the transcription start (Weber & May 1989). Men with idiopathic osteoporosis had low serum IGF-I, and this was associated with homozygosity for a specific allele of the IGF-I microsatellite characterized by 192 CA repeats (Rosen *et al.* 1998). This genotype has then been shown to be associated with lower peak serum IGF-I levels and lower femoral cross-sectional area in 85 pubertal boys and girls (Gilsanz *et al.* 1999). However, these findings were not confirmed in healthy postmenopausal Japanese women (Miyao *et al.* 1998), in 363 premenopausal women (Takacs *et al.* 1999), in 256 healthy Caucasian adolescents of both genders below the age of 20 (Berg *et al.* 2000), nor in 100 adult young males at the peak bone mass (Rizzoli *et al.* 2000). Hence, despite the clear role of the growth hormone-IGF-I axis on the development and maintenance of peak bone mass, the adequacy of IGF-I CA repeat polymorphisms as susceptibility markers for the risk of low bone mass/osteoporosis requires further evidence.

Other hormones/receptor gene polymorphisms

Several other polymorphic genes coding for hormones and/or the receptor have recently been investigated in relation to bone mass (Table 1) (Huizenga *et al.* 1998, Masi *et al.* 1998, Miyao *et al.* 1998, Rosen *et al.* 1998, Taboulet *et al.* 1998, Willing *et al.* 1998, Hosoi *et al.* 1999, Kanzawa *et al.* 1999, Sowers *et al.* 1999, Heishi *et al.* 2000) and some clearly deserve further attention. An allelic variant causing an amino acid change in the C-terminal domain of the calcitonin receptor gene has been identified (Masi *et al.* 1998, Taboulet *et al.* 1998, Tsukamoto & Emi 1998). In two of these studies, heterozygous Rr postmenopausal women had an apparently higher BMD as compared with

either homozygote RR or rr. The lack of a clear allele dosage effect casts some doubts on the pertinence of these observations. Polymorphisms in the glucocorticoid receptor gene resulting in an amino acid change have been identified in 6% of a Dutch population and associated with an increased sensitivity to glucocorticoids resulting in a trend towards decreased BMD (Huizenga *et al.* 1998). This polymorphic locus carries a great potential to explain major interindividual variations in the rate of bone loss in glucocorticoid-treated patients.

The PTH gene has been shown to display polymorphisms (Mullersman *et al.* 1992, Hosoi *et al.* 1999, Kanzawa *et al.* 1999). In the study by Hosoi *et al.* (1999), heterozygosity in an intronic polymorphism in the PTH gene was found to be associated with higher lumbar spine BMD in 383 healthy postmenopausal Japanese women. However, serum PTH levels were absolutely identical among homozygotes and heterozygotes. Moreover, a small study in 91 healthy Caucasian women who were premenopausal at entry and were prospectively investigated for a median period of 20 years with repeated bone radiographs has recently suggested that PTH gene polymorphisms could explain 7–9% of the variance in bone dimensions and their changes with age, such as the cross-sectional cortical area of long bones (Gong *et al.* 1999). Regarding PTH/PTHrP receptor, although microsatellite markers in the vicinity of the PTH receptor 1 gene have clearly identified this locus as an important potential determinant of bone mass (Duncan *et al.* 1999), to date no polymorphisms have directly been identified in this gene sequence in relation to BMD.

Eventually, variable number tandem repeats (AGC) $_n$ in the androgen receptor gene have recently been shown to be associated with BMD at the femoral neck and lumbar spine as well as with femoral neck BMD changes over 3 years in 261 pre- and perimenopausal women (Sowers *et al.* 1999). Due to the increasing evidence of a contribution of androgens in bone mass determination in women as much as in men, these data are of great interest and clearly deserve confirmation in other cohorts.

Beyond hormones

A number of polymorphic genes coding for proteins acting beyond the hormone-receptor level seem to offer great promise in explaining some of the variance in the susceptibility to osteoporosis. Among them, functional allelic variants in the genes coding for the TGF- β 1 and IL-6, two cytokines acting downstream of the ER to directly regulate bone resorption and/or formation (Manolagas

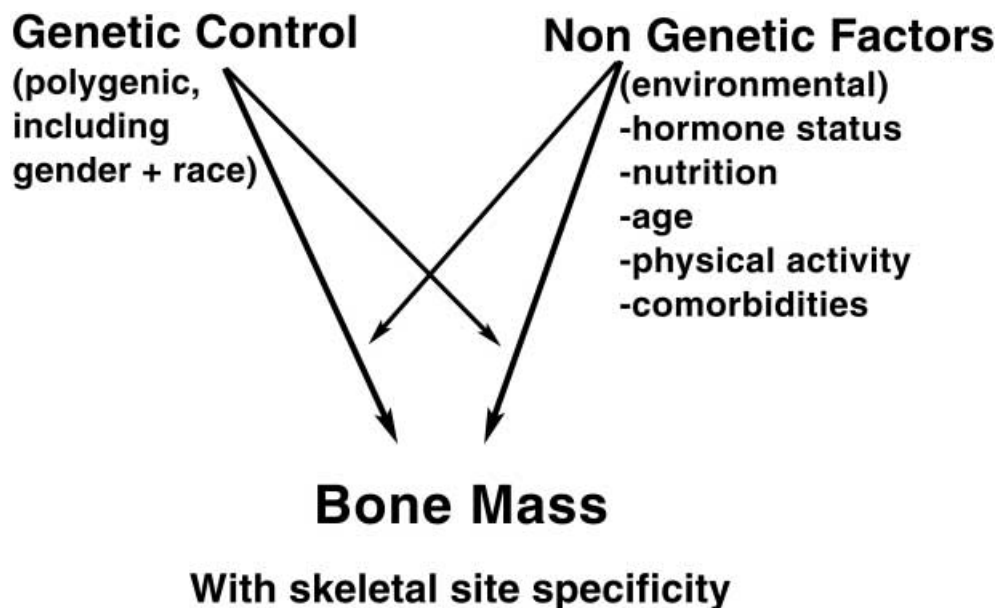

FIGURE 4. Interaction of genetic and non-genetic factors on bone mass.

1998), have recently been associated with osteoporosis and/or the rate of bone turnover in postmenopausal women. Thus, a common T>C transition polymorphism in the TGF- β 1 gene exon 1 is significantly associated with serum TGF- β 1 concentrations as well as the prevalence of osteoporosis in 239 unrelated postmenopausal Japanese women and susceptibility to fracture (Yamada *et al.* 1998, 2000). Moreover, in the same cohort, this polymorphism has been associated with the rate of bone loss as well as the response to vitamin D supplements (Yamada *et al.* 2000). A higher BMD was also observed in adolescents with the CC genotype, suggesting that this polymorphism could influence peak bone mass as well (Yamada *et al.* 1999). However, these findings require confirmation in populations of other ethnic origin. Another important, although rare, polymorphism in the TGF- β 1 gene occurring as a one-base (C) deletion in intron 4 has also been associated with severe osteoporosis and increased bone turnover in Caucasians (Langdahl *et al.* 1997, Bertoldo *et al.* 2000).

A common G>C polymorphism at position -174 in the IL-6 gene promoter has recently been shown to affect the gene transcriptional activity (Fishman *et al.* 1998). These allelic variants influence the level of bone resorption, as evaluated by a marker of collagen I degradation – the serum C-telopeptide of type I collagen – in postmenopausal women (Ferrari *et al.* 2000).

CONCLUSIONS

Bone mass gain during growth as well as postmenopausal and age-related bone loss display skeletal-site specificity in terms of magnitude and kinetics. Bone strength, and thereby fracture risk, depends on bone size, volumetric bone density, microarchitecture, and intrinsic bony tissue properties. The risk of osteoporosis depends on the achievement of peak bone mass, which is mostly determined by changes in bone size with minimal modifications in volumetric density, and in the amount of bone loss, which is mainly the consequence of alteration in volumetric bone density and in microarchitecture. All these processes are controlled by complex and selective genetic, hormonal, nutritional and other environmental factors, which tightly interact (Fig. 4). Because of the multiple influences on bone homeostasis and the heterogeneity of the mechanisms governing skeletal growth and bone loss, the genetic control of bone mass implicates numerous genes of variable importance during an individual's lifespan. The recent emergence of candidate genes, particularly controlling hormone levels and their receptors, associated with BMD and/or bone remodeling, has opened new concepts in the comprehension of the pathophysiology of osteoporosis. Among these genes, allelic polymorphisms for the receptors recognizing the vitamin D active metabolite (calcitriol), estradiol, and PTH could be associated with bone mass. Most importantly, these

polymorphic genes, as well as those coding for TGF- β and IL-6, have a potential interest to understand, and eventually predict, the individual response to anti-osteoporotic therapies. Thus, the possible implication of the PTH receptor 1 gene in the response to PTH raises great interest with respect to the recently reported effects of PTH in the prevention of fracture risk (Neer *et al.* 2000). However, any of these polymorphic loci is very unlikely to represent *per se* a definite marker of osteoporosis, particularly since their influence cannot be dissociated from environmental factors (Ferrari *et al.* 1998e). Therefore, to reliably appraise the role of genetics in osteoporosis as a highly complex model, one has to gather information from different sources. These include association studies in well-defined demographically and homogeneous populations, and randomized controlled trials looking at the bone response to hormonal and/or environmental changes, combined with experimental investigations assessing the molecular mechanisms implicated in the interaction between genotype and phenotype.

ACKNOWLEDGEMENTS

We thank Mrs M Perez for her invaluable help in the preparation of the manuscript. The work from our group quoted in this review was supported by the Swiss National Science Foundation (grants no. 32-32415-91 and no. 31-40758-94).

REFERENCES

- Ames SK, Ellis KJ, Gunn SK, Copeland KC & Abrams SA 1999 Vitamin D receptor gene *FokI* polymorphism predicts calcium absorption and bone mineral density in children. *Journal of Bone and Mineral Research* **14** 740-746.
- Ammann P, Rizzoli R, Meyer JM & Bonjour JP 1996 Bone density and shape as determinants of bone strength in IGF-I and/or pamidronate-treated ovariectomized rats. *Osteoporosis International* **6** 219-227.
- Aniansson A, Zetterberg C, Hedberg M & Henriksson K 1984 Impaired muscle function with aging. *Clinical Orthopaedics and Related Research* **191** 193-201.
- Arai H, Miyamoto KI, Taketani Y, Yamamoto H, Iemori Y, Morita K, Tonai T, Nishisho T, Mori S & Takeda E 1997 A vitamin D receptor gene polymorphism in the translation initiation codon: effect on protein activity and relation to bone mineral density in Japanese women. *Journal of Bone and Mineral Research* **12** 915-921.
- Bagi CM, DeLeon E, Ammann P, Rizzoli R & Miller SC 1996 Histo-anatomy of the proximal femur in rats: impact of ovariectomy on bone mass, structure, and stiffness. *Anatomical Record* **245** 633-644.
- Bagi CM, Ammann P, Rizzoli R & Miller SC 1997 Effect of estrogen deficiency on cancellous and cortical bone structure and strength of the femoral neck in rats. *Calcified Tissue International* **61** 336-344.
- Barger-Lux MJ, Heaney RP, Hayes J, DeLuca HF, Johnson ML & Gong G 1995 Vitamin D receptor gene polymorphisms, bone mass, body size, and vitamin D receptor density. *Calcified Tissue International* **57** 161-162.
- Barthe N, Basse-Cathalinat B, Meunier PJ, Ribot C, Marchandise X, Sabatier JP, Braillon P, Thevenot J & Sutter B 1998 Measurement of bone mineral density in mother-daughter pairs for evaluating the family influence on bone mass acquisition: a GRIO survey. *Osteoporosis International* **8** 379-384.
- Berg JP, Lehmann EH, Stakkestad JA, Haug E & Halse J 2000 IGF-I gene microsatellite polymorphisms and serum levels of insulin-like growth factor I (IGF-I), IGF-binding protein 3 and bone mineral density in young individuals. *Proceedings of the Annual Meeting of the Endocrine Society*. Abstract no. 1743.
- Bertoldo F, D'Agruma L, Furlan F, Colapietro F, Lorenzi MT, Maiorano N, Iolascon A, Zelante L, Locascio V & Gasparini P 2000 Transforming growth factor-beta1 gene polymorphism, bone turnover, and bone mass in Italian postmenopausal women. *Journal of Bone and Mineral Research* **15** 634-639.
- Bilezikian JP, Kurland ES & Rosen CJ 1999 Male skeletal health and osteoporosis. *Trends in Endocrinology and Metabolism* **10** 244-250.
- Bonjour JP & Rizzoli R 1996 Bone acquisition in adolescence. In *Osteoporosis*, pp 465-476. Eds R Marcus, D Feldman & J Kelsey. San Diego: Academic Press.
- Bonjour JP, Theintz G, Buchs B, Slosman D & Rizzoli R 1991 Critical years and stages of puberty for spinal and femoral bone mass accumulation during adolescence. *Journal of Clinical Endocrinology and Metabolism* **73** 555-563.
- Bonjour JP, Carrié AL, Ferrari S, Clavien H, Slosman D, Theintz G & Rizzoli R 1997 Calcium enriched foods and bone mass growth in prepubertal girls: a randomized, double-blind, placebo-controlled trial. *Journal of Clinical Investigation* **99** 1287-1294.
- Canalis E, McCarthy TL & Centrella M 1991 Growth factors and cytokines in bone cell metabolism. *Annual Review of Medicine* **42** 17-24.
- Carani C, Qin K, Simoni M, Faustini-Fustini M, Serpente S, Boyd J, Korach KS & Simpson ER 1997 Effect of testosterone and estradiol in a man with aromatase deficiency. *New England Journal of Medicine* **337** 91-95.
- Castaneda C, Charnley JM, Evans WJ & Crim MC 1995 Elderly women accommodate to a low-protein diet with losses of body cell mass, muscle function, and immune response. *American Journal of Clinical Nutrition* **62** 30-39.
- Caverzasio J & Bonjour JP 1989 Insulin-like growth factor I stimulates Na-dependent Pi transport in cultured kidney cells. *American Journal of Physiology* **257** F712-F717.
- Caverzasio J, Montessuit C & Bonjour JP 1990 Stimulatory effect of insulin-like growth factor-I on renal Pi transport and plasma 1,25-dihydroxyvitamin D₃. *Endocrinology* **127** 453-459.
- Chapuy MC, Arlot ME, Duboeuf F, Brun J, Crouzet B, Arnaud S, Delmas PD & Meunier PJ 1992 Vitamin D₃ and calcium to prevent hip fractures in elderly women. *New England Journal of Medicine* **327** 1637-1642.
- Chevalley T, Rizzoli R, Nydegger V, Slosman D, Rapin CH, Michel JP, Vasey H & Bonjour JP 1994 Effects of calcium supplements on femoral bone mineral density and vertebral fracture rate in vitamin-D-replete elderly patients. *Osteoporosis International* **4** 245-252.
- Chevalley T, Rizzoli R, Manen D, Caverzasio J & Bonjour JP 1998 Arginine increases insulin-like growth factor-I production and collagen synthesis in osteoblast-like cells. *Bone* **23** 103-109.

- Christakos S, Raval-Pandya M, Wernyj RP & Yang W 1996 Genomic mechanisms involved in the pleiotropic actions of 1,25-dihydroxyvitamin D₃. *Biochemical Journal* **316** 361–371.
- Cohen-Solal ME, Baudoin C, Omouri M, Kuntz D & De Vernejoul MC 1998 Bone mass in middle-aged osteoporotic men and their relatives: familial effect. *Journal of Bone and Mineral Research* **13** 1909–1914.
- Cooper GS & Umbach DM 1996 Are vitamin D receptor polymorphisms associated with bone mineral density? A meta-analysis. *Journal of Bone and Mineral Research* **11** 1841–1849.
- Danielson ME, Cauley JA, Baker CE, Newman AB, Dorman JS, Towers JD & Kuller LH 1999 Familial resemblance of bone mineral density (BMD) and calcaneal ultrasound attenuation: the BMD in mothers and daughters study. *Journal of Bone and Mineral Research* **14** 102–110.
- Dawson-Hughes B, Harris SS & Finneran S 1995 Calcium absorption on high and low calcium intakes in relation to vitamin D receptor genotype. *Journal of Clinical Endocrinology and Metabolism* **80** 3657–3661.
- Dawson-Hughes B, Harris SS, Krall EA & Dallal GE 1997 Effect of calcium and vitamin D supplementation on bone density in men and women 65 years of age or older. *New England Journal of Medicine* **337** 670–676.
- Deng HW, Li J, Li JL, Johnson M, Gong G, Davis KM & Recker RR 1998 Change of bone mass in postmenopausal Caucasian women with and without hormone replacement therapy is associated with vitamin D receptor and estrogen receptor genotypes. *Human Genetics* **103** 576–585.
- Drinkwater BL, Nilson K, Chesnut CH III, Bremner WJ, Shainholtz S & Southworth MB 1984 Bone mineral content of amenorrheic and eumenorrheic athletes. *New England Journal of Medicine* **311** 277–281.
- Duncan EL, Brown MA, Sinsheimer J, Bell J, Carr AJ, Wordsworth BP & Wass JA 1999 Suggestive linkage of the parathyroid receptor type 1 to osteoporosis. *Journal of Bone and Mineral Research* **14** 1993–1999.
- Eccleshall TR, Garnero P, Gross C, Delmas PD & Feldman D 1998 Lack of correlation between start codon polymorphism of the vitamin D receptor gene and bone mineral density in premenopausal French women: the OFELY study. *Journal of Bone and Mineral Research* **13** 31–35.
- Ensrud KE, Palermo L, Black DM, Cauley J, Jergas M, Orwoll ES, Nevitt MC, Fox KM & Cummings SR 1995 Hip and calcaneal bone loss increase with advancing age: longitudinal results from the study of osteoporotic fractures. *Journal of Bone and Mineral Research* **10** 1778–1787.
- Ensrud KE, Stone K, Cauley JA, White C, Zmuda JM, Nguyen TV, Eisman JA & Cummings SR 1999 Vitamin D receptor gene polymorphisms and the risk of fractures in older women. For the Study of Osteoporotic Fractures Research Group. *Journal of Bone and Mineral Research* **14** 1637–1645.
- Ensrud KE, Duong T, Cauley JA, Heaney RP, Worl RL, Harris E & Cummings SR 2000 Low fractional calcium absorption increases the risk for hip fracture in women with low calcium intake. Study of Osteoporotic Fractures Research Group. *Annals of Internal Medicine* **132** 345–353.
- Ferrari S, Rizzoli R, Chevalley T, Slosman D, Eisman JA & Bonjour JP 1995 Vitamin-D-receptor-gene polymorphisms and change in lumbar-spine bone mineral density. *Lancet* **345** 423–424.
- Ferrari S, Bonjour JP & Rizzoli R 1998a The vitamin D receptor gene and calcium metabolism. *Trends in Endocrinology and Metabolism* **9** 259–265.
- Ferrari S, Rizzoli R, Slosman D & Bonjour JP 1998b Familial resemblance for bone mineral mass is expressed before puberty. *Journal of Clinical Endocrinology and Metabolism* **83** 358–361.
- Ferrari S, Rizzoli R, Slosman D & Bonjour JP 1998c Do dietary calcium and age explain the controversy surrounding the relationship between bone mineral density and vitamin D receptor gene polymorphisms. *Journal of Bone and Mineral Research* **13** 925–930.
- Ferrari S, Rizzoli R, Manen D, Slosman D & Bonjour JP 1998d Vitamin D receptor gene start codon polymorphisms (*FokI*) and bone mineral density: interaction with age, dietary calcium and 3'-end region polymorphisms. *Journal of Bone and Mineral Research* **13** 363–370.
- Ferrari S, Rizzoli R & Bonjour JP 1998e Heritable and nutritional influences on bone mineral mass. *Aging* **10** 205–213.
- Ferrari S, Manen D, Bonjour JP, Slosman D & Rizzoli R 1999 Bone mineral mass and calcium and phosphate metabolism in young men: relationships with vitamin D receptor allelic polymorphisms. *Journal of Clinical Endocrinology and Metabolism* **84** 2043–2048.
- Ferrari S, Garnero P, Emond S, Montgomery H, Humphries SE & Greenspan S 2001 A functional polymorphic variant in the interleukin-6 gene promoter associated with low bone resorption in postmenopausal women. *Arthritis and Rheumatism* (In Press).
- Feskanich D, Hunter DJ, Willett WC, Hankinson SE, Hollis BW, Hough HL, Kelsey KT & Colditz GA 1998 Vitamin D receptor genotype and the risk of bone fractures in women. *Epidemiology* **9** 535–539.
- Fishman D, Faulds G, Jeffery R, Mohamed-Ali V, Yudkin JS, Humphries S & Woo P 1998 The effect of novel polymorphisms in the interleukin-6 (IL-6) gene on IL-6 transcription and plasma IL-6 levels, and an association with systemic-onset juvenile chronic arthritis. *Journal of Clinical Investigation* **102** 1369–1376.
- Fournier PE, Rizzoli R, Slosman DO, Theintz G & Bonjour JP 1997 Asynchrony between the rates of standing height gain and bone mass accumulation during puberty. *Osteoporosis International* **7** 525–532.
- Froesch ER, Schmid C, Schwander J & Zapf J 1985 Actions of insulin-like growth factors. *Annual Review of Physiology* **47** 443–467.
- Garn SM, Wagner B, Rohmann CG & Ascoli W 1967 Further evidence for continuing bone expansion. *American Journal of Physical Anthropology* **26** 313–318.
- Garn SM, Rohmann CG, Wagner B & Ascoli W 1968 Continuing bone growth throughout life: a general phenomenon. *American Journal of Physical Anthropology* **28** 219–222.
- Garnero P, Borel O, Sornay-Rendu E & Delmas PD 1995 Vitamin D receptor gene polymorphisms do not predict bone turnover and bone mass in healthy premenopausal women. *Journal of Bone and Mineral Research* **10** 1283–1288.
- Garnero P, Arden NK, Griffiths G, Delmas PD & Spector TD 1996a Genetic influence on bone turnover in postmenopausal twins. *Journal of Clinical Endocrinology and Metabolism* **81** 140–146.
- Garnero P, Borel O, Sornay-Rendu E, Arlot ME & Delmas PD 1996b Vitamin D receptor gene polymorphisms are not related to bone turnover, rate of bone loss, and bone mass in postmenopausal women: the OFELY study. *Journal of Bone and Mineral Research* **11** 827–834.
- Gennari L, Becherini L, Masi L, Mansani R, Gonnelli S, Cepollaro C, Martini S, Montagnani A, Lentini G, Becorpi AM & Brandi ML 1998 Vitamin D and estrogen receptor allelic variants in Italian postmenopausal women: evidence of multiple gene contribution to bone mineral density.

- Journal of Clinical Endocrinology and Metabolism* **83** 939–944.
- Geusens P, Cantatore F, Nijs J, Proesmans W, Emma F & Dequeker J 1991 Heterogeneity of growth of bone in children at the spine, radius and total skeleton. *Growth, Development and Aging* **55** 249–256.
- Giguère Y, Dodin S, Blanchet C, Morgan K & Rousseau F 2000 The association between heel ultrasound and hormone replacement therapy is modulated by a two-locus vitamin D and estrogen receptor genotype. *Journal of Bone and Mineral Research* **15** 1076–1084.
- Gilsanz V 1998 Phenotype and genotype of osteoporosis. *Trends in Endocrinology and Metabolism* **9** 184–190.
- Gilsanz V, Gibbens DT, Roe TF, Carlson M, Senac MO, Boechat MI, Huang HK, Schulz EE, Libanati CR & Cann CC 1988 Vertebral bone density in children: effect of puberty. *Radiology* **166** 847–850.
- Gilsanz V, Roe TF, Mora S, Costin G & Goodman WG 1991 Changes in vertebral bone density in black girls and white girls during childhood and puberty. *New England Journal of Medicine* **325** 1597–1600.
- Gilsanz V, Kovanlikaya A, Costin G, Roe TF, Sayre J & Kaufman F 1997 Differential effect of gender on the sizes of the bones in the axial and appendicular skeletons. *Journal of Clinical Endocrinology and Metabolism* **82** 1603–1607.
- Gilsanz V, Skaggs DL, Kovanlikaya A, Sayre J, Luiza Loro M, Kaufman F & Korenman SG 1998 Differential effect of race on the axial and appendicular skeletons of children. *Journal of Clinical Endocrinology and Metabolism* **83** 1420–1427.
- Gilsanz V, Rogers J, Bilezikian JP, Friez JK & Rosen C 1999 A simple sequence repeat in the IGF-I gene and its relationship to serum IGF-I and peak bone mass in pupertal boys and girls. *Proceedings of the Annual Meeting of the American Endocrine Society*. Abstract no. OR23-2.
- Glastre C, Braillon P, David L, Cochat P, Meunier PJ & Delmas PD 1990 Measurement of bone mineral content of the lumbar spine by dual energy X-ray absorptiometry in normal children: correlations with growth parameters. *Journal of Clinical Endocrinology and Metabolism* **70** 1330–1333.
- Gong G, Johnson ML, Barger-Lux MJ & Heaney RP 1999 Association of bone dimensions with a parathyroid hormone gene polymorphism in women. *Osteoporosis International* **9** 307–311.
- Gong Y, Vikkula M, Boon L, Liu J, Beighton P, Ramesar R, Peltonen L, Somer H, Hirose T, Dallapiccola B, De Paepe A, Swoboda W, Zabel B, Superti-Furga A, Steinmann B, Brunner HG, Jans A, Boles RG, Adkins W, van den Boogaard MJ, Olsen BR & Warman ML 1996 Osteoporosis–pseudoglioma syndrome, a disorder affecting skeletal strength and vision, is assigned to chromosome region 11q12–13. *American Journal of Human Genetics* **59** 146–151.
- Goodman-Gruen D & Barrett-Connor E 1997 Epidemiology of insulin-like factor-I in elderly men and women. The Rancho Bernardo Study. *American Journal of Epidemiology* **145** 970–976.
- Graafmans WC, Lips P, Ooms ME, van Leeuwen JP, Pols HAP & Uitterlinden AG 1997 The effect of vitamin D supplementation on the bone mineral density of the femoral neck is associated with vitamin D receptor genotype. *Journal of Bone and Mineral Research* **12** 1241–1245.
- Greendale GA, Edelstein S & Barrett-Connor E 1997 Endogenous sex steroids and bone mineral density in older women and men: the Rancho Bernardo study. *Journal of Bone and Mineral Research* **12** 1833–1843.
- Gregg EW, Wolf RL, Kriska AM, Ferrell RE, Salamone LM, Black D, Kuller LH & Cauley JA 1996 Does the relationship between vitamin D receptor genotypes and bone parameters vary with physical activity level? *Journal of Bone and Mineral Research* **11** (Suppl 1) S210.
- Gregg EW, Kriska AM, Salamone LM, Wolf RL, Roberts MM, Ferrell RE, Anderson SJ, Kuller LH & Cauley JA 1999 Correlates of quantitative ultrasound in the Women's Healthy Lifestyle Project. *Osteoporosis International* **10** 416–424.
- Gross C, Eccleshall TR, Malloy PJ, Villa ML, Marcus R & Feldman D 1996 The presence of a polymorphism at the translation initiation site of the vitamin D receptor gene is associated with low bone mineral density in postmenopausal Mexican-American women. *Bone and Mineral Research* **11** 1850–1855.
- Hammerman MR 1987 Insulin-like growth factors and aging. *Endocrinology and Metabolism Clinics of North America* **16** 995–1011.
- Han KO, Moon G, Kang YS, Chung HY, Min HK & Han IK 1997 Nonassociation of estrogen receptor genotypes with bone mineral density and estrogen responsiveness to hormone replacement therapy in Korean postmenopausal women. *Journal of Clinical Endocrinology and Metabolism* **82** 991–995.
- Han ZH, Palnitkar S, Rao DS, Nelson D & Parfitt AM 1996 Effects of ethnicity and age or menopause on the structure and geometry of iliac bone. *Journal of Bone and Mineral Research* **11** 1967–1975.
- Harris SS, Eccleshall TR, Gross C, Dawson-Hughes B & Feldman D 1997 The vitamin D receptor start codon polymorphism (FokI) and bone mineral density in premenopausal American black and white women. *Journal of Bone and Mineral Research* **12** 1043–1048.
- Haussler MR, Haussler CA, Jurutka PW, Thompson PD, Hsieh JC, Remus LS, Selznick SH & Whitfield GK 1997 The vitamin D hormone and its nuclear receptor: molecular actions and disease states. *Journal of Endocrinology* **154** S57–S73.
- Heishi M, Tazawa H, Matsuo T, Saruta T, Hanaoka M & Tsukamoto Y 2000 A novel Van91 I polymorphism in the 1st intron of the parathyroid hormone (PTH)/PTH-related peptide (PTHrP) receptor gene and its effect on the urinary cAMP response to PTH. *Biological and Pharmaceutical Bulletin* **23** 386–389.
- Hosoi T, Miyao M, Inoue S, Hoshino S, Shiraki M, Orimo H & Ouchi Y 1999 Association study of parathyroid hormone gene polymorphism and bone mineral density in Japanese postmenopausal women. *Calcified Tissue International* **64** 205–208.
- Huizenga NA, Koer JW, De Lange P, Pols HA, Stolk RP, Burger H, Grobbee DE, Brinkmann AO, De Jong FH & Lamberts SW 1998 A polymorphism in the glucocorticoid receptor gene may be associated with an increased sensitivity to glucocorticoids *in vivo*. *Journal of Clinical Endocrinology and Metabolism* **83** 144–151.
- Hustmyer F, Peacock M, Hui S, Johnston CC & Christian J 1994 Bone mineral density in relation to polymorphism at the vitamin D receptor gene locus. *Journal of Clinical Investigation* **94** 2130–2134.
- Johnson ML, Gong G, Kimberling W, Recker SM, Kimmel DB & Recker RB 1997 Linkage of a gene causing high bone mass to human chromosome 11 (11q12–13). *American Journal of Human Genetics* **60** 1326–1332.
- Jørgensen HL, Schøller J, Sand JC, Bjuring M, Hassager C & Christiansen C 1996 Relation of common allelic variation at vitamin D receptor locus to bone mineral density and postmenopausal bone loss: cross sectional and

- longitudinal population study. *British Medical Journal* **313** 586–590.
- Kanis JA, Devogelaer JP & Gennari C 1996 Practical guide for the use of bone mineral measurements in the assessment of treatment of osteoporosis: a position paper of the European Foundation for Osteoporosis and Bone Disease. The Scientific Advisory Board and the Board of National Societies. *Osteoporosis International* **6** 256–261.
- Kannus P, Palvanen M, Kaprio J, Parkkari J & Koskenvuo M 1999 Genetic factors and osteoporotic fractures in elderly people: prospective 25 year follow-up of a nationwide cohort of elderly Finnish twins. *British Medical Journal* **319** 1334–1337.
- Kanzawa M, Sugimoto T, Kobayashi T, Kobayashi A & Chihara K 1999 Parathyroid hormone gene polymorphisms in primary hyperparathyroidism. *Clinical Endocrinology* **50** 583–588.
- Katzman DK, Bachrach LK, Carter DR & Marcus R 1991 Clinical and anthropometric correlates of bone mineral acquisition in healthy adolescent girls. *Journal of Clinical Endocrinology and Metabolism* **73** 1332–1339.
- Kelly PJ, Eisman JA & Sambrook PN 1990 Interaction of genetic and environmental influences on peak bone density. *Osteoporosis International* **1** 56–60.
- Kelly PJ, Morrison NA, Sambrook PN, Nguyen TV & Eisman JA 1995 Genetic influences on bone turnover, bone density and fracture. *European Journal of Endocrinology* **133** 265–271.
- Khosla S, Atkinson EJ, Melton LJ 3rd & Riggs BL 1997 Effects of age and estrogen status on serum parathyroid hormone levels and biochemical markers of bone turnover in women: a population-based study. *Journal of Clinical Endocrinology and Metabolism* **82** 1522–1527.
- Kiel DP, Myers RH, Cupples A, Kong XF, Zhu XH, Ordovas J, Schaefer EJ, Felson DT, Rush D, Wilson PWF, Eisman JA & Holick MF 1997 The *BsmI* vitamin D receptor restriction fragment length polymorphism (bb) influences the effect of calcium intake on bone mineral density. *Journal of Bone and Mineral Research* **12** 1049–1057.
- Kikuchi R, Uemura T, Gorai I, Ohno S & Minaguchi H 1999 Early and late postmenopausal bone loss is associated with *BsmI* vitamin D receptor gene polymorphism in Japanese women. *Calcified Tissue International* **64** 102–106.
- Klotzbuecher CM, Ross PD, Landsman PB, Abbott TA 3rd & Berger M 2000 Patients with prior fractures have an increased risk of future fractures: a summary of the literature and statistical synthesis. *Journal of Bone and Mineral Research* **15** 721–739.
- Kobayashi S, Inoue S, Hosoi T, Ouchi Y, Shiraki M & Orimo H 1996 Association of bone mineral density with polymorphism of the estrogen receptor gene. *Journal of Bone and Mineral Research* **11** 306–311.
- Koller DL, Rodriguez LA, Christian JC, Slemenda CW, Econs MJ, Hui SL, Morin P, Conneally PM, Joslyn G, Curran ME, Peacock M, Johnston CC & Foroud T 1998 Linkage of a QTL contributing to normal variation in bone mineral density to chromosome 11q12–13. *Journal of Bone and Mineral Research* **13** 1903–1908.
- Krall EA & Dawson-Hughes B 1993 Heritable and life-style determinants of bone mineral density. *Journal of Bone and Mineral Research* **8** 1–9.
- Krall EA, Parry P, Lichter JB & Dawson-Hughes B 1995 Vitamin D receptor alleles and rates of bone loss: influences of years since menopause and calcium intake. *Journal of Bone and Mineral Research* **10** 978–984.
- Langdahl BL, Knudsen JY, Jensen HK, Gregersen N & Eriksen EF 1997 A sequence variation: 713–8 delC in the transforming growth factor-beta 1 gene has higher prevalence in osteoporotic women than in normal women and is associated with very low bone mass in osteoporotic women and increased bone turnover in both osteoporotic and normal women. *Bone* **20** 289–294.
- Langlois JA, Rosen CJ, Visser M, Hannan MT, Harris T, Wilson PW & Kiel DP 1998 Association between insulin-like growth factor I and bone mineral density in older women and men: the Framingham Heart Study. *Journal of Clinical Endocrinology and Metabolism* **83** 4257–4262.
- Laval-Jeantet AM, Bergot C, Carroll R & Garcia-Schaefer F 1983 Cortical bone senescence and mineral bone density of the humerus. *Calcified Tissue International* **35** 268–272.
- Lorentzon M, Lorentzon R & Nordstrom P 2000 Vitamin D receptor gene polymorphism is associated with birth height, growth to adolescence, and adult stature in healthy Caucasian men: a cross-sectional and longitudinal study. *Journal of Clinical Endocrinology and Metabolism* **85** 1666–1670.
- Luckey MM, Wallenstein S, Lapinski R & Meier DE 1996 A prospective study of bone loss in African-American and white women – a clinical research center study. *Journal of Clinical Endocrinology and Metabolism* **81** 2948–2956.
- Manolagas SC 1998 The role of IL-6 type cytokines and their receptors in bone. *Annals of the New York Academy of Sciences* **840** 194–204.
- Masi L, Becherini L, Colli E, Gennari L, Mansani R, Falchetti A, Becorpi AM, Cepollaro C, Gonnelli S, Tanini A & Brandi ML 1998 Polymorphisms of the calcitonin receptor gene are associated with bone mineral density in postmenopausal Italian women. *Biochemical and Biophysical Research Communications* **248** 190–195.
- Matkovic V, Jelic T, Wardlaw GM, Ilich JZ, Goel PK, Wright JK, Andon MB, Smith KT & Heaney RP 1994 Timing of peak bone mass in Caucasian females and its implication for the prevention of osteoporosis – inference from a cross-sectional model. *Journal of Clinical Investigation* **93** 799–808.
- Matsuyama T, Ishii S, Tokita A, Yabuta K, Yamamori S, Morrison NA & Eisman JA 1995 Vitamin D receptor genotypes and bone mineral density. *Lancet* **345** 1238–1239.
- Mazess RB, Barden HS, Ettinger M, Johnston C, Dawson-Hughes B, Baran D, Powell M & Nadelovitz M 1987 Spine and femur density using dual-photon absorptiometry in US white women. *Bone and Mineral* **2** 211–219.
- Miyao M, Hosoi T, Inoue S, Hoshino S, Shiraki M, Orimo H & Ouchi Y 1998 Polymorphism of insulin-like growth factor I gene and bone mineral density. *Calcified Tissue International* **63** 306–311.
- Mizunuma H, Hosoi T, Okano H, Soda M, Tokizawa T, Kagami I, Miyamoto S, Ibuki Y, Inoue S, Shiraki M & Ouchi Y 1997 Estrogen receptor gene polymorphism and bone mineral density at the lumbar spine of pre- and postmenopausal women. *Bone* **21** 379–383.
- Morrison NA, Qi JC, Tokita A, Kelly PJ, Crofts L, Nguyen TV, Sambrook PN & Eisman JA 1994 Prediction of bone density from vitamin D receptor alleles. *Nature* **367** 284–287.
- Mosekilde L & Mosekilde L 1990 Sex differences in age-related changes in vertebral body size, density and biomechanical competence in normal individuals. *Bone* **11** 67–73.
- Mullersman JE, Shields JJ & Saha K 1992 Characteristics of two novel polymorphisms at the human parathyroid hormone gene locus. *Human Genetics* **88** 589–592.
- Neer RM, Arnaud C, Zanchetta JR, Prince R, Gaich GA, Reginster JY, Hodsman AB, Erickson EF, Mellstrom D, Ish-Shalom *et al.* 2000 Recombinant human PTH [rhPTH(1-34)] reduces the risk of spine and non-spine fractures in postmenopausal osteoporosis. *Proceedings of the*

- Annual Meeting of the American Endocrine Society*. Abstract no. 173.
- Nguyen TV, Howard GM, Kelly PJ & Eisman JA 1998 Bone mass, lean mass, and fat mass: same genes or same environments? *American Journal of Epidemiology* **147** 3–16.
- Palmer G, Bonjour JP & Caverzasio J 1996 Stimulation of inorganic phosphate transport by insulin-like growth factor I and vanadate in opossum kidney cells is mediated by distinct protein tyrosine phosphorylation processes. *Endocrinology* **137** 4699–4705.
- Palmer G, Bonjour JP & Caverzasio J 1997 Expression of a newly identified phosphate transporter/retrovirus receptor in human SaOS-2 osteoblast-like cells and its regulation by insulin-like growth factor I. *Endocrinology* **138** 5202–5209.
- Parsons JT, Prentice A, Smith EA, Cole TJ & Compston JE 1996 Bone mineral mass consolidation in young British adults. *Journal of Bone and Mineral Research* **11** 264–274.
- Pinilla TP, Boardman KC, Bouxsein ML, Myers ER & Hayes WC 1996 Impact direction from a fall influences the failure load of the proximal femur as much as age-related bone loss. *Calcified Tissue International* **58** 231–235.
- Pocock NA, Eisman JA, Hopper JL, Yeates MG, Sambrook PN & Ebert S 1987 Genetic determinants of bone mass in adults. A twin study. *Journal of Clinical Investigation* **80** 706–710.
- Quesada JM, Coopmans W, Ruiz B, Aljama P, Jans I & Bouillon R 1992 Influence of vitamin D on parathyroid function in the elderly. *Journal of Clinical Endocrinology and Metabolism* **75** 494–501.
- Ralston SH 1997 What determines peak bone mass and bone loss? *Baillieres Clinical Rheumatology* **11** 479–494.
- Reichel H, Koeffler HP & Norman AW 1989 The role of the vitamin D endocrine system in health and disease. *New England Journal of Medicine* **320** 980–991.
- Riggs BL, Wahner HW, Melton LJ III, Richelson LS, Judd HL & Offord KP 1986 Rates of bone loss in the appendicular and axial skeletons of women: evidence for substantial vertebral bone loss before menopause. *Journal of Clinical Investigation* **77** 1487–1491.
- Riggs BL, Khosla S & Melton LJ III 1998 A unitary model for involutional osteoporosis: estrogen deficiency causes both type I and type II osteoporosis in postmenopausal women and contributes to bone loss in aging men. *Journal of Bone and Mineral Research* **13** 763–773.
- Rizzoli R & Bonjour JP 1997 Hormones and bones. *Lancet* **349** sI20–sI23.
- Rizzoli R, Slosman D & Bonjour JP 1995 Dual energy X-ray absorptiometry of lumbar spine and proximal femur in the diagnosis and follow-up of osteoporosis. *American Journal of Medicine* **98** 33S–35S.
- Rizzoli R, Ferrari S, Rosen C, Manen D & Bonjour JP 2000 IGF-I gene 5' polymorphism influences serum IGF-I levels in relation to dietary calcium intake in healthy young males. *Journal of Bone and Mineral Research* **15** (Suppl 1) S364.
- Rodin A, Murby B, Smith MA, Caleffi M, Fentiman I, Chapman MG & Fogelman I 1990 Premenopausal bone loss in the lumbar spine and neck of femur: a study of 225 Caucasian women. *Bone* **11** 1–5.
- Rosen CJ & Donahue LR 1995 Insulin-like growth factors: potential therapeutic options for osteoporosis. *Trends in Endocrinology and Metabolism* **6** 235–241.
- Rosen CJ, Kurland ES, Vereault D, Adler RA, Rackoff PJ, Craig WY, Witte S, Rogers J & Bilezikian JP 1998 Association between serum insulin growth factor-I (IGF-I) and a simple sequence repeat in IGF-I gene: implications for genetic studies of bone mineral density. *Journal of Clinical Endocrinology and Metabolism* **83** 2286–2290.
- Rubin LA, Hawker GA, Peltekova VD, Fielding LJ, Ridout R & Cole DE 1999 Determinants of peak bone mass: clinical and genetic analyses in a young female Canadian cohort. *Journal of Bone and Mineral Research* **14** 633–643.
- Sainz J, Van Tornout JM, Loro ML, Sayre J, Roe TF & Gilsanz V 1997 Vitamin D-receptor gene polymorphisms and bone density in prepubertal American girls of Mexican descent. *New England Journal of Medicine* **337** 77–82.
- Salamone LM, Glynn NW, Black DM, Ferrell RE, Palermo L, Epstein RS, Kuller LH & Cauley JA 1996 Determinants of premenopausal bone mineral density: the interplay of genetic and lifestyle factors. *Journal of Bone and Mineral Research* **11** 1557–1565.
- Salmen T, Heikkinen AM, Mahonen A, Kroger H, Komulainen M, Saarikoski S, Honkanen R & Maenpaa PH 2000 Early postmenopausal bone loss is associated with *PvuII* estrogen receptor gene polymorphism in Finnish women: effect of hormone replacement therapy. *Journal of Bone and Mineral Research* **15** 315–321.
- Schmid C & Ernst M 1992 Insulin-like growth factors. In *Cytokines and Bone Metabolism*, pp 229–265. Ed M Gowen. Boca Raton, Ann Arbor, London: CRC Press.
- Schürch MA, Rizzoli R, Slosman D, Vadas L, Vergnaud P & Bonjour JP 1998 Protein supplements increase serum insulin-like growth factor-I levels and attenuate proximal femur bone loss in patients with recent hip fracture. A randomized, double-blind, placebo-controlled trial. *Annals of Internal Medicine* **128** 801–809.
- Seeman E 1997 From density to structure: growing up and growing old on the surfaces of bone. *Journal of Bone and Mineral Research* **12** 509–521.
- Seeman E & Hopper JL 1997 Genetic and environmental components of the population variance in bone density. *Osteoporosis International* **7** (Suppl 3) S10–S16.
- Seeman E, Hopper JL, Bach LA, Cooper ME, Parkinson E, McKay J & Jerums G 1989 Reduced bone mass in daughters of women with osteoporosis. *New England Journal of Medicine* **320** 554–558.
- Seeman E, Szmukler GI, Formica C, Tsalamandris C & Mestrovic R 1992 Osteoporosis in anorexia nervosa – the influence of peak bone density, bone loss, oral contraceptive use, and exercise. *Journal of Bone and Mineral Research* **7** 1467–1474.
- Seeman E, Hopper JL, Young NR, Formica C, Goss P & Tsalamandris C 1996 Do genetic factors explain associations between muscle strength, lean mass, and bone density? A twin study. *American Journal of Physiology* **279** E320–E327.
- Slemenda CW, Christian JC, Williams CJ, Norton JA & Johnston CC 1991 Genetic determinants of bone mass in adult women: a reevaluation of the twin model and the potential importance of gene interaction on heritability estimates. *Journal of Bone and Mineral Research* **6** 561–567.
- Slemenda CW, Turner CH, Peacock M, Christian JC, Sorbel J, Hui SL & Johnston CC 1996a The genetics of proximal femur geometry, distribution of bone mass and bone mineral density. *Osteoporosis International* **6** 178–182.
- Slemenda CW, Longcope C, Peacock M, Hui S & Johnston CC 1996b Sex steroids, bone mass and bone loss: a prospective study of pre-, peri-, and postmenopausal women. *Journal of Clinical Investigation* **97** 14–21.
- Slemenda CW, Longcope C, Zhou L, Hui SL, Peacock M & Johnston C 1997 Sex steroids and bone mass in older men: positive associations with serum estrogens and negative associations with androgens. *Journal of Clinical Investigation* **100** 1755–1759.

- Smith EP, Boyd J, Frank GR, Takahashi H, Cohen RM, Specker B, Williams TC, Lubahn DB & Korach KS 1994 Estrogen resistance caused by a mutation in the estrogen-receptor gene in a man. *New England Journal of Medicine* **331** 1056–1061.
- Snieder H, MacGregor AJ & Spector TD 1998 Genes control the cessation of a woman's reproductive life: a twin study of hysterectomy and age at menopause. *Journal of Clinical Endocrinology and Metabolism* **83** 1875–1880.
- Sowers M, Willing M, Burns T, Deschenes S, Hollis B, Crutchfield M & Jannausch M 1999 Genetic markers, bone mineral density, and serum osteocalcin levels. *Journal of Bone and Mineral Research* **14** 1411–1419.
- Taboulet J, Frenkian M, Frenco JL, Feingold N, Jullienne A & De Vernejoul MC 1998 Calcitonin receptor polymorphism is associated with a decreased fracture risk in post-menopausal women. *Human Molecular Genetics* **7** 2129–2133.
- Takacs I, Koller DL, Peacock M, Christian JC, Hui SL, Conneally PM, Johnston CC Jr, Foroud T & Econs MJ 1999 Sibling pair linkage and association studies between bone mineral density and the insulin-like growth factor I gene locus. *Journal of Clinical Endocrinology and Metabolism* **84** 4467–4471.
- Tao C, Yu T, Garnett S, Briody J, Knight J, Woodhead H & Cowell CT 1998 Vitamin D receptor alleles predict growth and bone density in girls. *Archives of Diseases in Childhood* **79** 488–493.
- Theintz G, Buchs B, Rizzoli R, Slosman D, Clavien H, Sizonenko PC & Bonjour JP 1992 Longitudinal monitoring of bone mass accumulation in healthy adolescents: evidence for a marked reduction after 16 years of age at the levels of lumbar spine and femoral neck in female subjects. *Journal of Clinical Endocrinology and Metabolism* **75** 1060–1065.
- Tokita A, Matsumoto H, Morrison NA, Tawa T, Miura Y, Fukamauchi K, Mitsuhashi N, Irimoto M, Yamamori S, Miura M, Watanabe T, Kuwabara Y, Yabuta K & Eisman JA 1996 Vitamin D receptor alleles, bone mineral density and turnover in premenopausal Japanese women. *Journal of Bone and Mineral Research* **11** 1003–1009.
- Trotter M & Dixon BB 1974 Sequential changes in weight, density, and percentage ash weight of human skeletons from an early fetal period through old age. *Anatomical Record* **179** 1–18.
- Tsukamoto K & Emi M 1998 A polymorphic CA repeat sequence at the human calcitonin locus. *Journal of Human Genetics* **43** 146–147.
- Turner CH, Hsieh YF, Muller R, Bouxsein ML, Baylink DJ, Rosen CJ, Grynbas MD, Donahue LR & Beamer WG 2000 Genetic regulation of cortical and trabecular bone strength and microstructure in inbred strains of mice. *Journal of Bone and Mineral Research* **15** 1126–1131.
- Tylavsky FA, Bortz AD, Hancock RL & Anderson JJB 1989 Familial resemblance of radial bone mass between premenopausal mothers and their college-age daughters. *Calcified Tissue International* **45** 265–272.
- Uitterlinden AG, Pols HAP, Burger H, Huang Q, Van Daele PLA, Van Duijn CM, Hofman A, Birkenhäger JC & Van Leeuwen JPTM 1996 A large-scale population-based study of the association of vitamin D receptor gene polymorphisms with bone mineral density. *Journal of Bone and Mineral Research* **11** 1241–1248.
- Vanderschueren D, Van Herck E, Nijs J, Ederveen AG, De Coster R & Bouillon R 1997 Aromatase inhibition impairs skeletal modeling and decreases bone mineral density in growing male rats. *Endocrinology* **138** 2301–2307.
- Vandevyver C, Vanhoof J, Declercq K, Stinissen P, Vandervorst C, Michiels L, Cassiman JJ, Boonen S, Raus J & Geusens P 1999 Lack of association between estrogen receptor genotypes and bone mineral density, fracture history, or muscle strength in elderly women. *Journal of Bone and Mineral Research* **14** 1576–1582.
- Weber JL & May PE 1989 Abundant class of human DNA polymorphisms which can be typed using the polymerase chain reaction. *American Journal of Human Genetics* **44** 388–396.
- Willing M, Sowers M, Aron D, Clark MK, Burns T, Bunten C, Crutchfield M, D'Agostino D & Jannausch M 1998 Bone mineral density and its change in white women: estrogen and vitamin D receptor genotypes and their interaction. *Journal of Bone and Mineral Research* **13** 695–705.
- Yamada Y, Miyauchi A, Goto J, Takagi Y, Okuizumi H, Kanematsu M, Hase M, Takai H, Harada A & Ikeda K 1998 Association of a polymorphism of the transforming growth factor-beta1 gene with genetic susceptibility to osteoporosis in postmenopausal Japanese women. *Journal of Bone and Mineral Research* **13** 1569–1576.
- Yamada Y, Hosoi T, Makimoto F, Tanaka H, Seino Y & Ikeda K 1999 Transforming growth factor beta-1 gene polymorphism and bone mineral density in Japanese adolescents. *American Journal of Medicine* **106** 477–479.
- Yamada Y, Harada A, Hosoi T, Miyauchi A, Ikeda K, Ohta H & Shiraki M 2000 Association of transforming growth factor beta1 genotype with therapeutic response to active vitamin D for postmenopausal osteoporosis. *Journal of Bone and Mineral Research* **15** 415–420.
- Zmuda JM, Cauley JA, Danielson ME, Wolf RL & Ferrell RE 1997 Vitamin D receptor gene polymorphisms, bone turnover, and rates of bone loss in older African-American women. *Journal of Bone and Mineral Research* **12** 1446–1452.
- Zmuda JM, Cauley JA & Ferrell RE 1999 Recent progress in understanding the genetic susceptibility to osteoporosis. *Genetic Epidemiology* **16** 356–367.

RECEIVED 8 September 2000

ACCEPTED 14 November 2000