



Introduction to Basic Human Genetics

Professor Hanan Hamamy
Department of Genetic Medicine and Development
Geneva University
Switzerland

Training Course in Sexual and Reproductive Health Research
Geneva 2016

Contents

- Categories of genetic diseases
- Birth defects (Congenital Disorders)
- Impact of genetic diseases
- DNA structure and mutations: basic principles



Spectrum of Human Disease

- Human diseases are caused by a multitude of genetic and environmental factors which act together
- In certain conditions such as Down syndrome, genetic factors predominate, while in tuberculosis for example, environmental factors predominate
- Most chronic non-communicable conditions such as schizophrenia and diabetes are caused by an interaction of both genetic and environmental factors

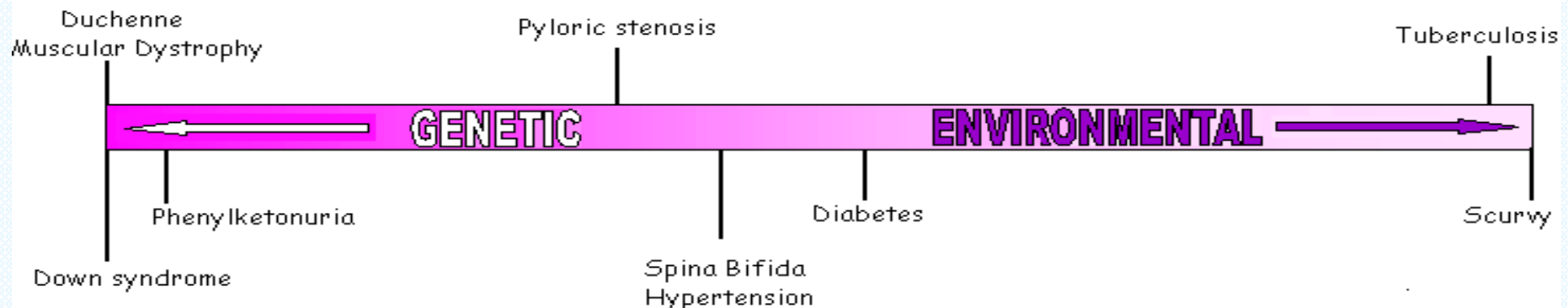

Categories of Genetic Diseases

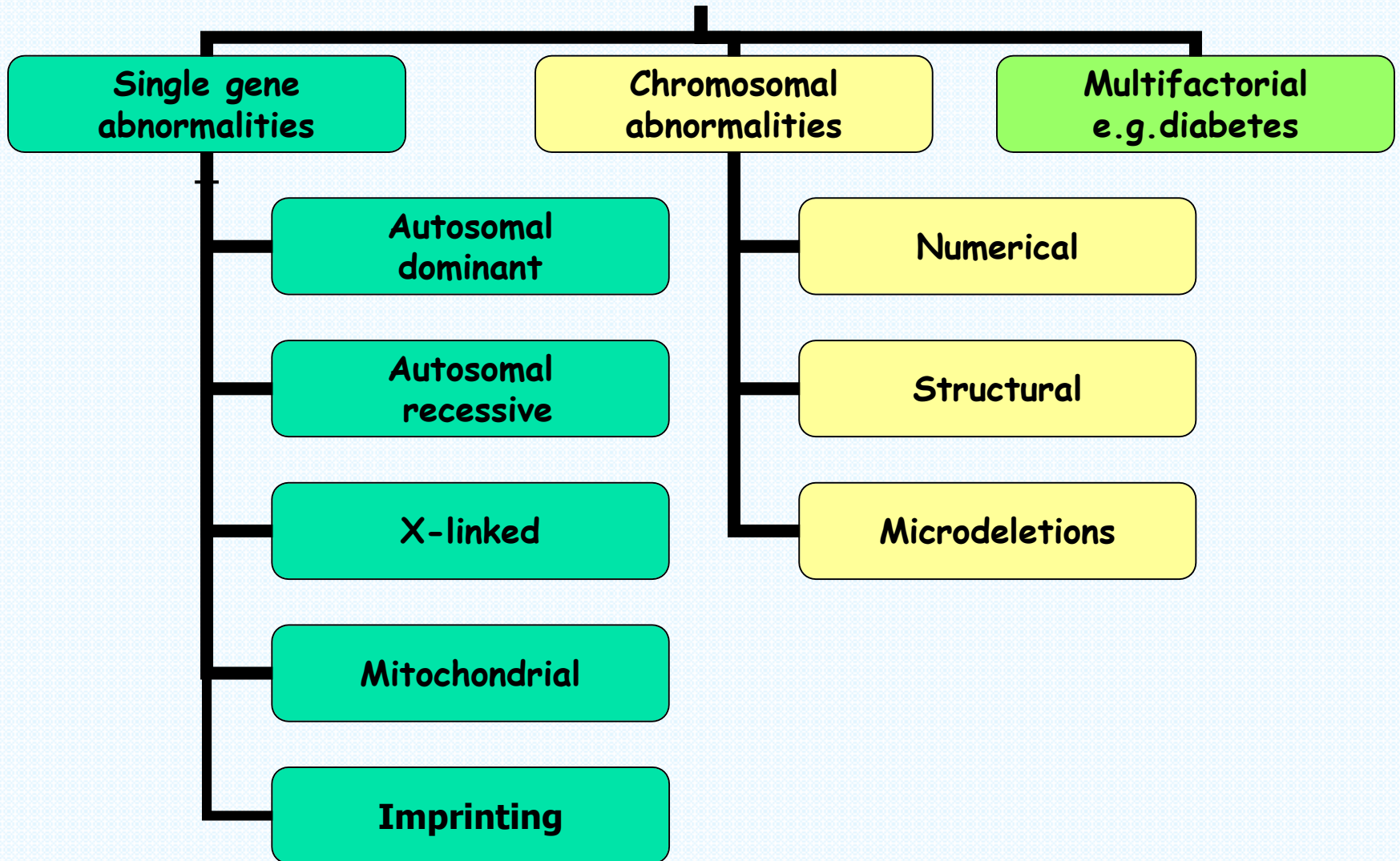

Categories of Genetic Diseases

- Single gene or unifactorial or Mendelian disorders: examples: thalassemias, sickle cell anemia, cystic fibrosis, albinism
- Chromosomal disorders such as Down syndrome, Turner syndrome
- Multifactorial disorders : both genetic and environmental factors play a role in causing the disease such as diabetes, asthma, schizophrenia and most congenital malformations (for example, congenital heart defects, club foot, cleft palate)

Family history and construction of a pedigree could point to the category of genetic disease in the family

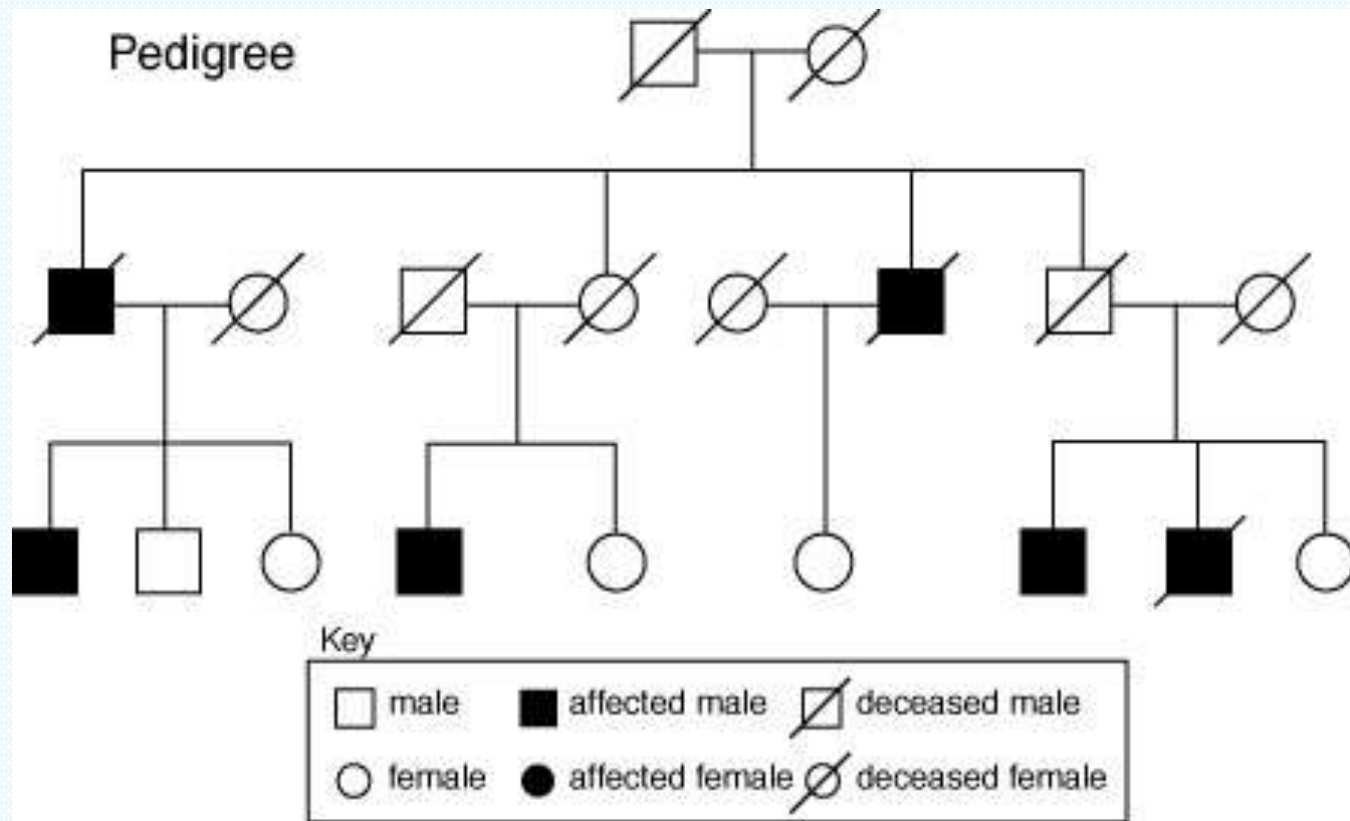

Birth defects (Congenital Disorders)

- According to the World Health Organization, the term congenital disorder includes any morphological, functional and biochemical-molecular defect that may develop in the embryo and fetus from conception until birth, whether detected at birth or later.
- This term is synonymous with the term birth defect used in the United States

Underlying causes of birth defects

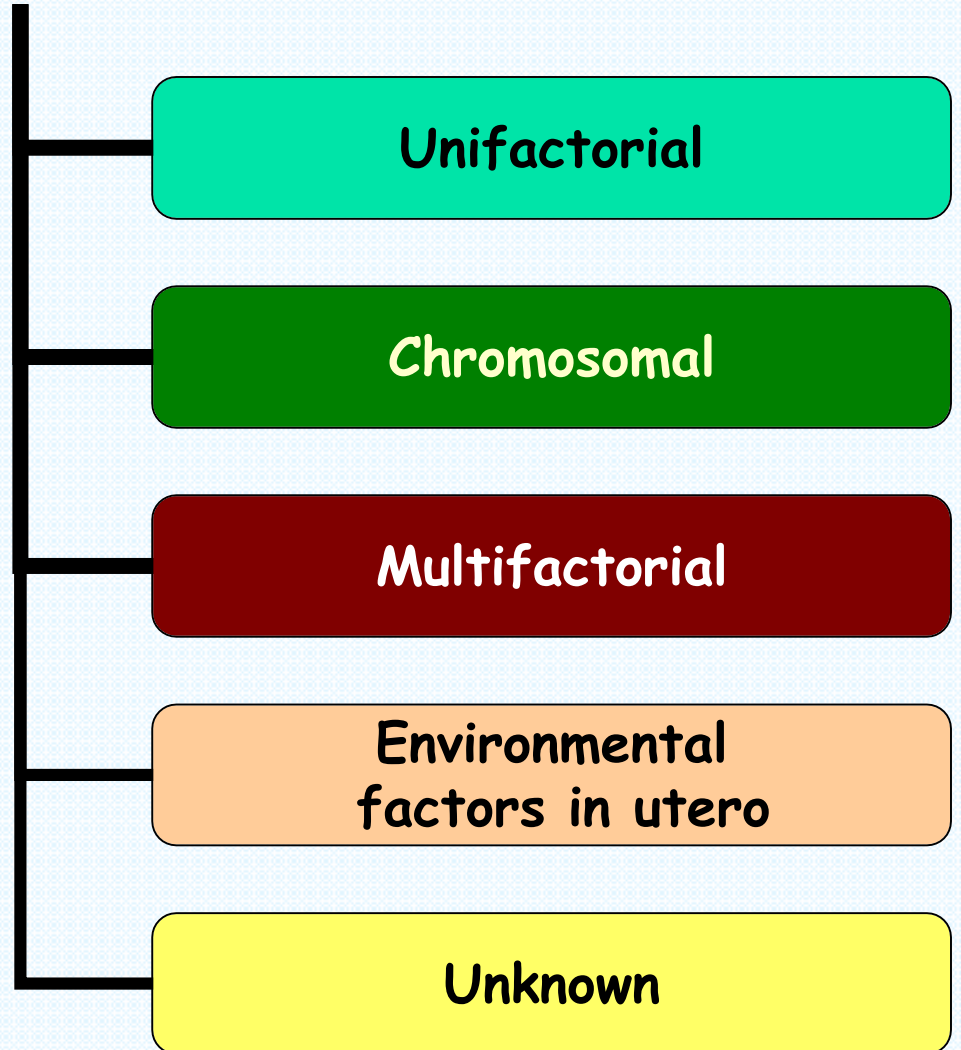

Classification of Congenital Disorders (Birth Defects)

Congenital abnormality (CA), or malformation (e.g. congenital heart defect)

Disability (eg. intellectual)

Fetal disease (e.g. fetal toxoplasmosis)

Genetic disease (e.g. Down syndrome)

Intrauterine growth retardation (idiopathic)

Rates of congenital disorders

- Of all neonates, 2-3% have at least one major congenital abnormality, at least 50% of which are caused exclusively or partially by genetic factors.
- Chromosome abnormalities occur in about 0.6% of neonates.
- Single-gene disorders occur in about 1% of neonates (could be higher in highly consanguineous populations).
- A chromosome abnormality is present in 40-50% of all recognized first-trimester pregnancy loss. Approximately 1 in 6 of all pregnancies results in spontaneous miscarriage.

Impact of genetic diseases

- Genetic disorders account for 50% of all childhood blindness, 50% of all childhood deafness and 50% of all cases of severe learning difficulty.
- Approximately 1% of all malignancy is caused by single-gene inheritance, and between 5% and 10% of common cancers such as breast, colon and ovary have a strong hereditary component.
- Taking into account common diseases as diabetes and hypertension (multifactorial disorders) , it has been estimated that over 50% of the older adult population will have a genetically determined medical problem.

Prevalent disorders

The 4 most serious and prevalent genetic and congenital disorders are:

- Hemoglobin disorders (thalassemia and sickle cell anemia) and G6PD deficiency
- Down syndrome
- Neural tube defects
- Congenital heart defects

DNA

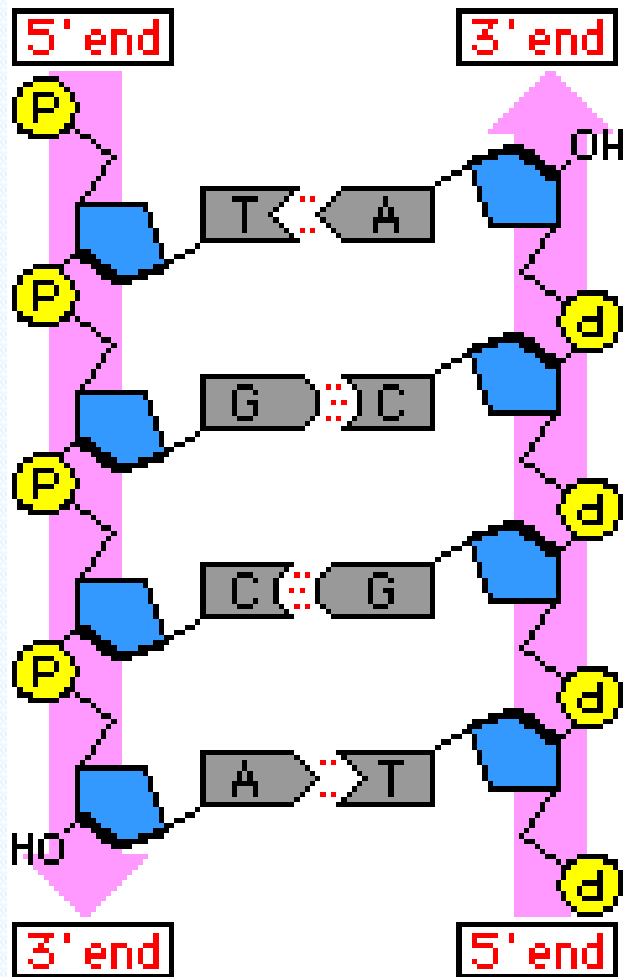

- DNA molecule is composed of two chains of nucleotides arranged in a double helix. The backbone of each chain is formed by phosphodiester bonds between the 3' and 5' carbons of adjacent sugars, the two chains being held together by hydrogen bonds between the nitrogenous bases adenine (A), guanine (G), cytosine (C) and thymine (T)
- The arrangement of the bases in the DNA molecule shows specific pairing of the base pairs: (G) in one chain always pairs with (C) in the other chain and (A) always pairs with (T).

Genes

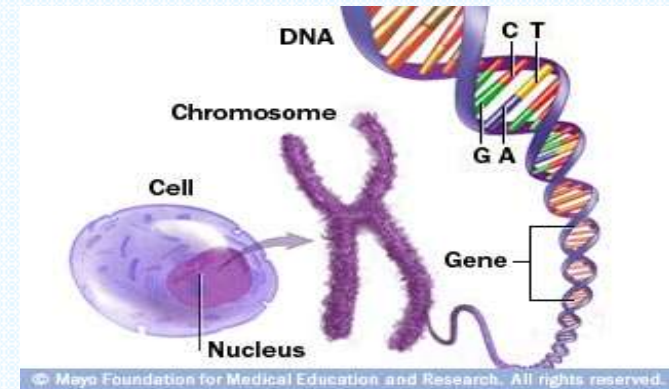

- It is estimated that there are approximately 20,000 protein coding genes in the nuclear genome
- These unique single-copy genes in humans represent less than 2% of the genome
- There are 37 mitochondrial genes in the cytoplasm that are only inherited from the mother

Structure of a gene

- The gene is formed of a DNA segment of coding regions called exons and non-coding regions called introns. The sequence of bases in the exons determine the sequence of aminoacids and hence the protein structure

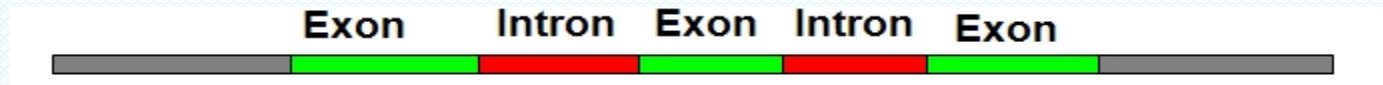

Gene Mutations

- A *mutation* is defined as a change in the genetic material. Mutations can arise through exposure to mutagenic agents, or spontaneously through errors in DNA replication and repair.
- *Somatic* mutations may cause adult-onset disease such as cancer but cannot be transmitted to offspring. A mutation in *gonadal* tissue or a *gamete* can be transmitted to future generations.

Types of DNA mutations

- Substitution: replacement of a single nucleotide by another
- Deletion: loss of one or more nucleotides
- Insertion: addition of one or more nucleotides
- Expansion of trinucleotide repeat sequences

Effects of mutations on the protein

- Silent mutation (synonymous): replacement of a single nucleotide by another but with no change in the amino acid
- Missense (non synonymous) replacement of a single nucleotide by another with change in the amino acid
- Nonsense: (non synonymous) replacement of a single nucleotide by another which leads to a change from a codon for an amino acid to a stop codon and truncation of the polypeptide chain
- Frameshift: deletion or insertion of a base leading to change in all subsequent sequence of nucleotides and change in the protein

DNA Sequence Variation in a Gene Can Change the Protein Produced by the Genetic Code

Gene A from Person 1



Protein Products



Gene A from Person 2

Codon change made no difference in amino acid sequence



Gene A from Person 3

Codon change resulted in a different amino acid at position 2



OR



Missense mutation

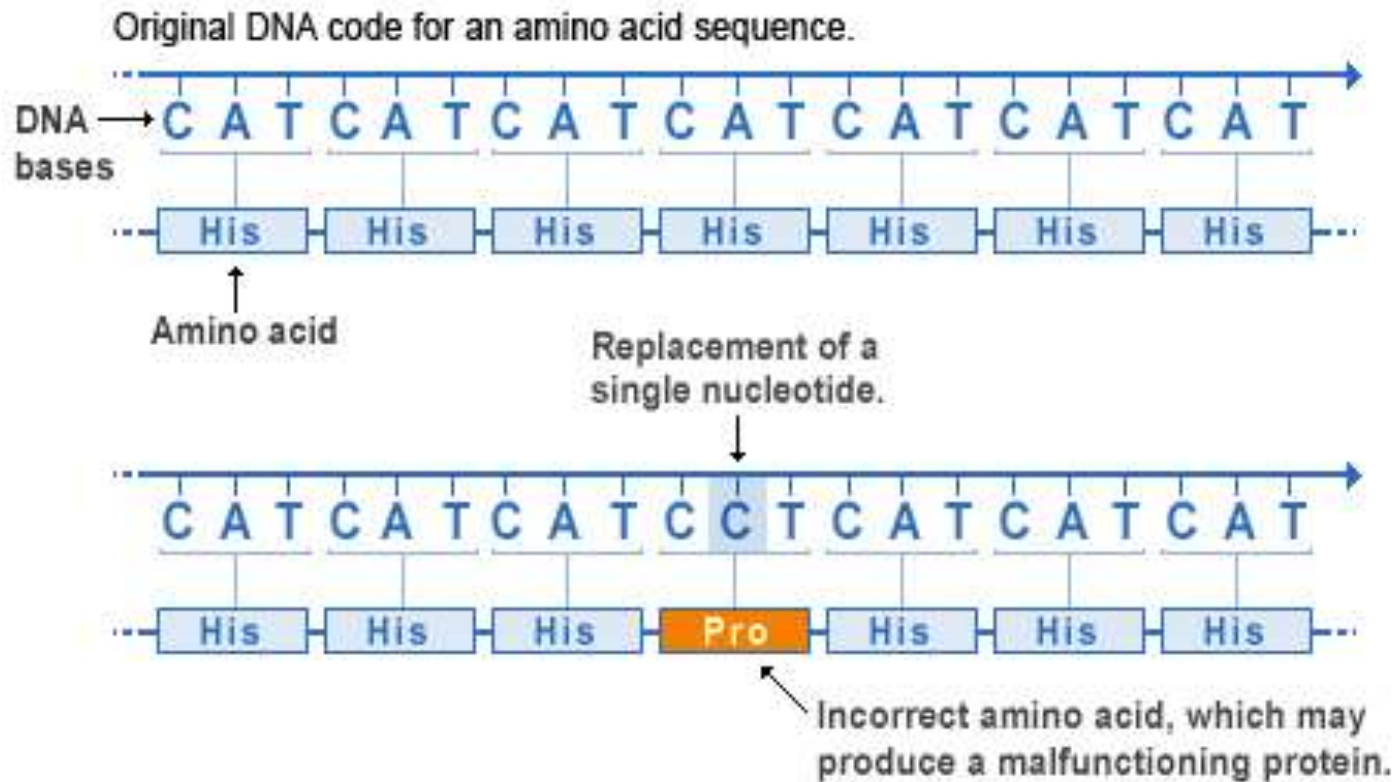

Nonsense mutation

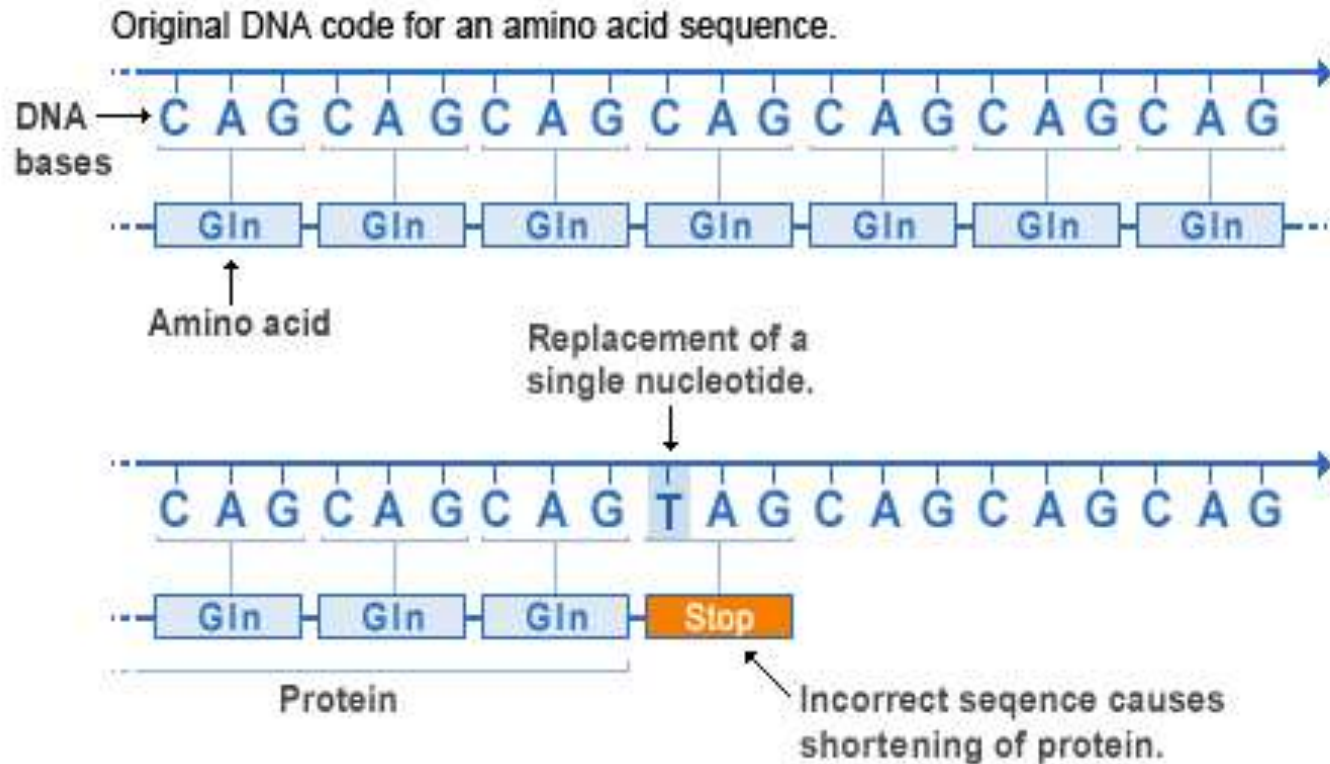

Insertion mutation

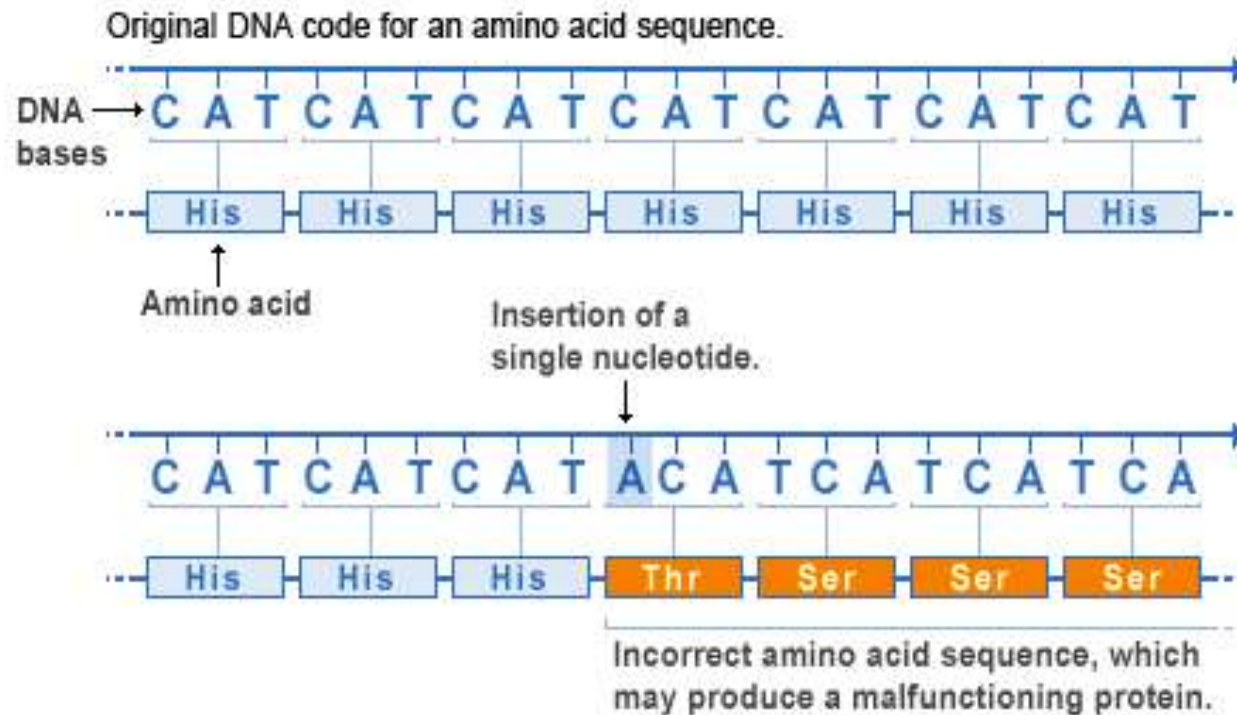

Deletion mutation

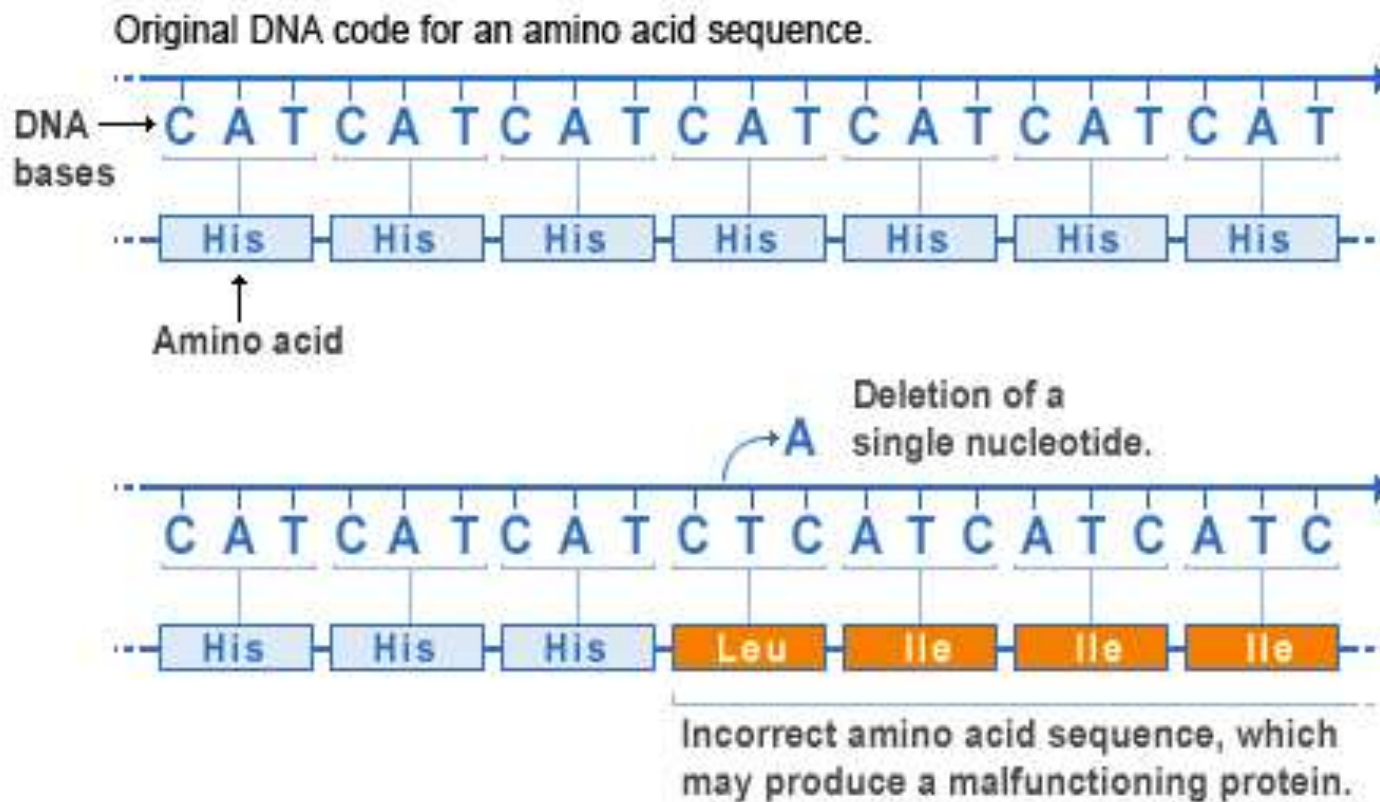

Repeat expansion mutation

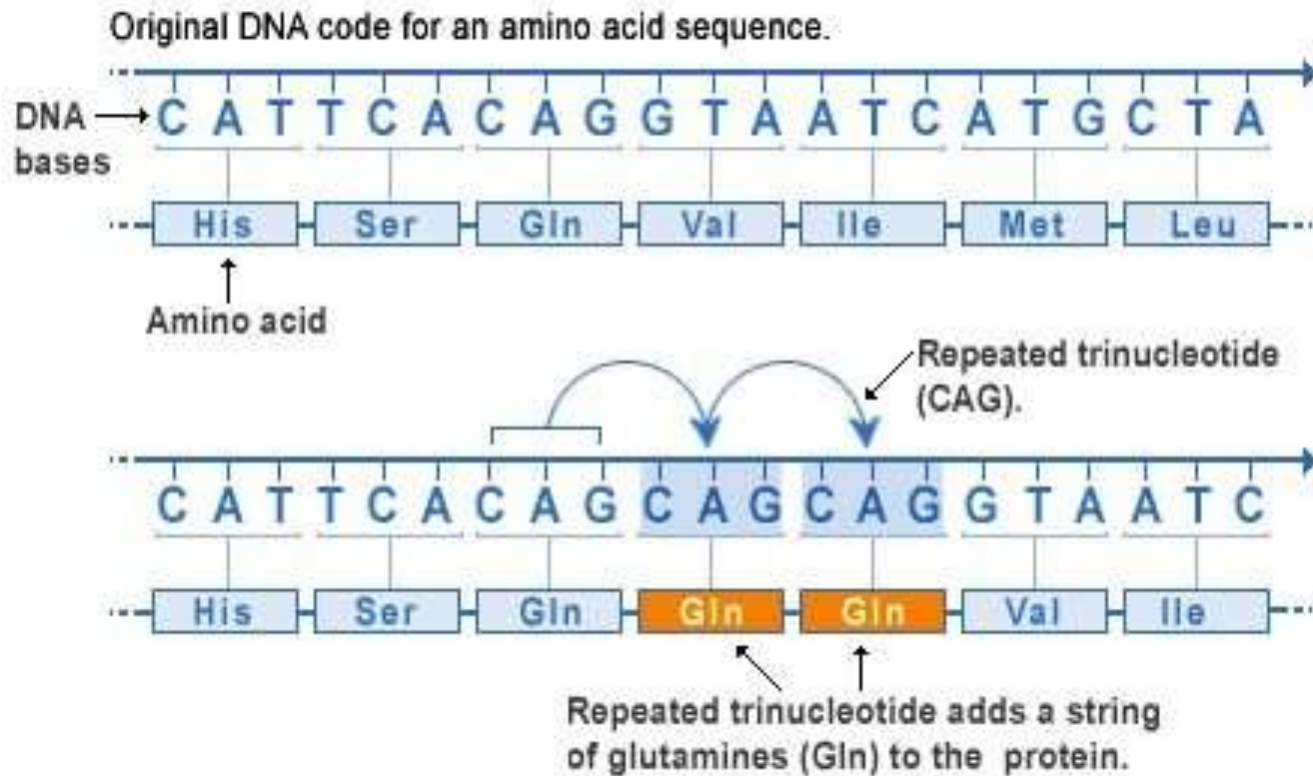

Factors implicated in mutagenesis

- **Ionizing radiation** includes electromagnetic waves of very short wavelength (X-rays and γ rays), and high-energy particles (α particles, β particles and neutrons).
- **Chemical mutagens** : In humans, chemical mutagenesis may be more important than radiation in producing genetic damage. Experiments have shown that certain chemicals, such as mustard gas, formaldehyde, benzene, some basic dyes and food additives, are mutagenic in animals.
- **Defective DNA repair**: The occurrence of mutations in DNA, if left unrepaired, would have serious consequences for both the individual and subsequent generations.

Cell Cycle

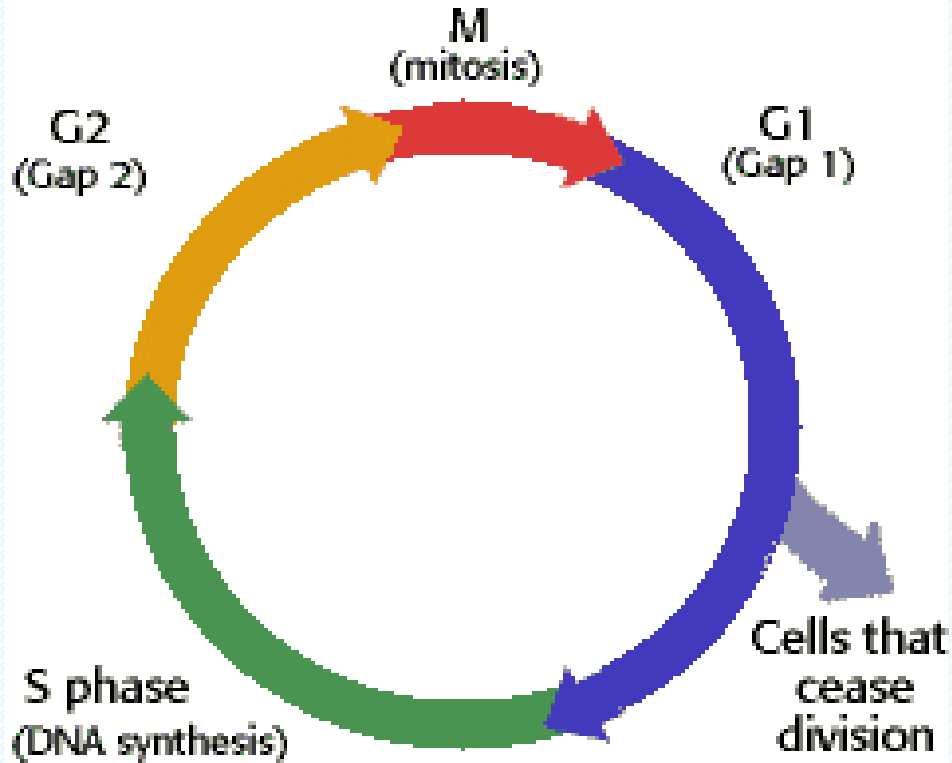

The cell passes through 2 stages:

1. Mitosis=cell division
2. Interphase: divided into G1, S and G2
 - G1 is the period for protein synthesis
 - S is the period for DNA replication

Chromosomes

- The human genome is the complete set of human genetic information stored as DNA sequences within the 23 chromosome pairs of the cell nucleus, and in a small DNA molecule within the Mitochondria in the cytoplasm.
- Chromosomes include 22 pairs of autosomes and one pair of sex chromosomes that is XX in the female and XY in the male.

Chromosomes can only be visualised under the microscope during mitosis (46,XX in female and 46,XY in male)

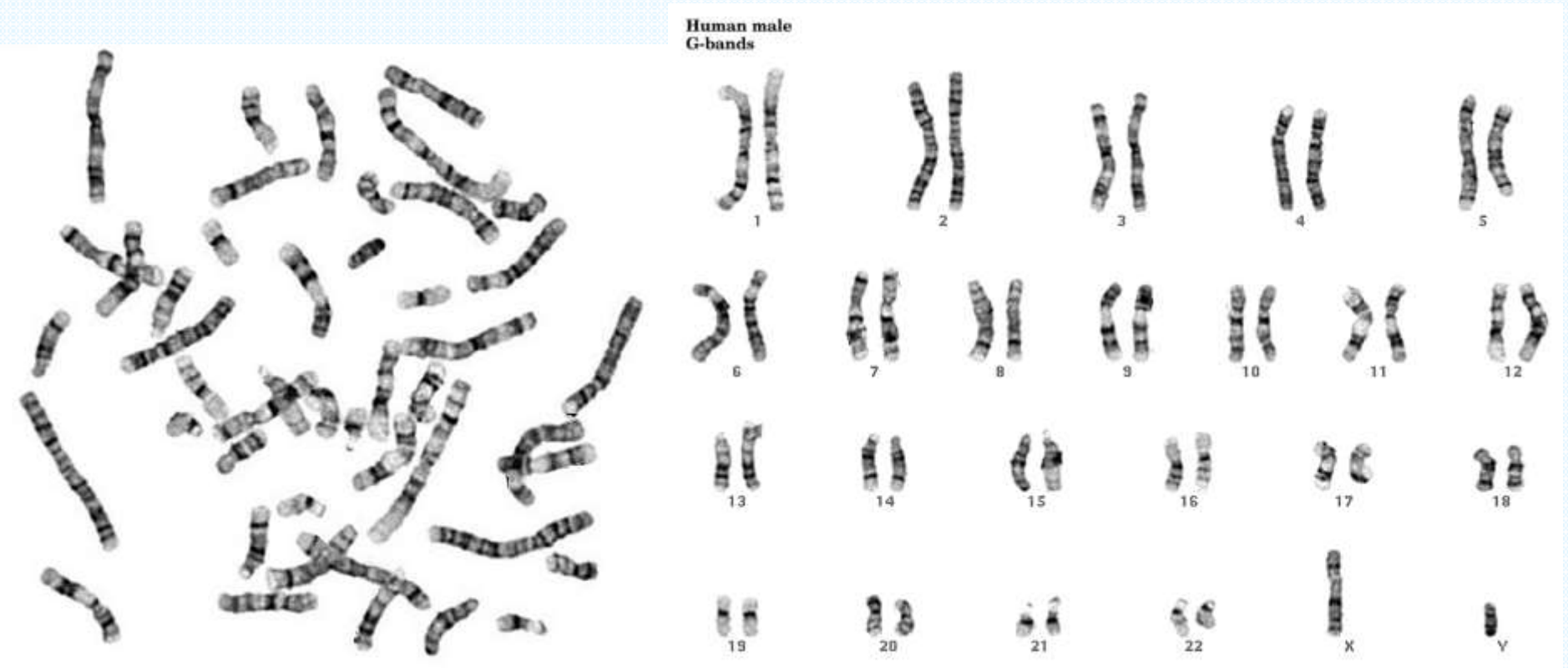

Metaphase plate
(chromosomes of one cell as
seen under the microscope)

Karyotype (chromosomes
arranged in a special way)

Chromosome types



Metacentric chromosome=
centromere in
middle
chromosomes
1,2,3,19,20

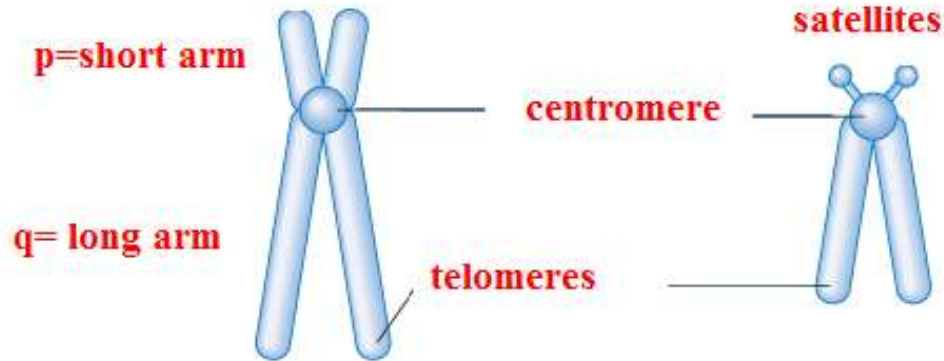

submetacentric chromosome=
centromere between middle
and one end
chromosomes
4,5,6,7,8,9,10,11,12,16,17,18,X

Acrocentric chromosomes =
centromere at one end
chromosomes 13,14,15,21,22,Y

X and Y chromosomes

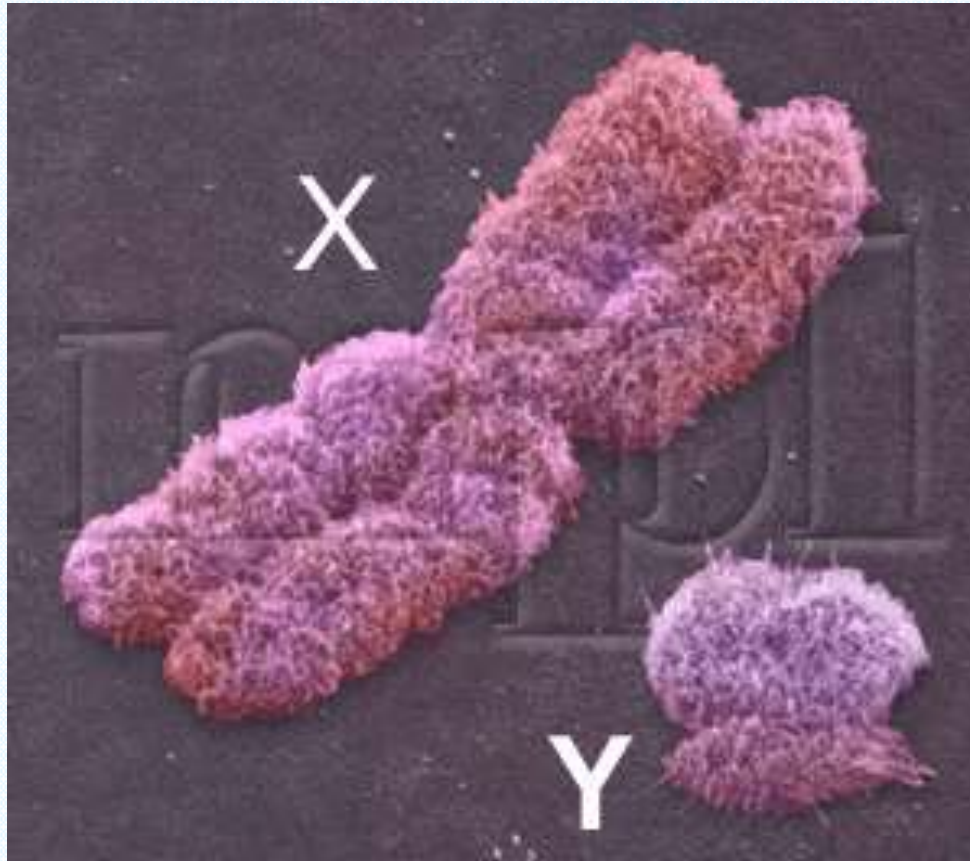

Conclusions

When a baby is suspected to have a congenital disorder, it is important to differentiate between single gene, chromosomal and multifactorial disorders because the methods of investigations differ and the risk of recurrence in future pregnancies differs.